

# LP8861-Q1 Low-EMI Automotive LED Driver With Four 100-mA Channels

## 1 Features

- Qualified for Automotive Applications
- AECQ100 Qualified With the Following Results:
  - Device Temperature Grade 1:  $-40^{\circ}\text{C}$  to  $+125^{\circ}\text{C}$  Ambient Operating Temperature
- Input Voltage Operating Range 4.5 V to 40 V
- Four High-Precision Current Sinks
  - Current Matching 1% (Typical)
  - LED String Current up to 100 mA/Channel
  - Dimming Ratio of 10 000:1 at 100 Hz
- Integrated Boost/SEPIC Converter for LED String Power
  - Output Voltage up to 45 V
  - Switching Frequency 300 kHz to 2.2 MHz
  - Switching Synchronization Input
  - Spread Spectrum for Lower EMI
- Power-Line FET Control for Inrush Current Protection and Standby Energy Saving
- Extensive Fault Detection and Tolerance Features
  - Fault Output
  - Input Voltage OVP, UVLO, and OCP
  - Open and Shorted LED Fault Detection
  - Automatic LED Current Reduction With External Temperature Sensor
  - Thermal Shutdown
- Minimum Number of External Components

## 2 Applications

- Backlight for:
  - Automotive Infotainment
  - Automotive Instrument Clusters
  - Smart Mirrors
  - Heads-Up Displays (HUD)
  - Central Information Displays (CID)
  - Audio-Video Navigation (AVN)

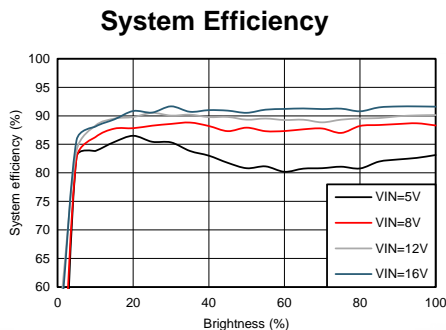

## 3 Description

The LP8861-Q1 is an automotive high-efficiency, low-EMI, easy-to-use LED driver with integrated boost/SEPIC converter. It has four high-precision current sinks that can provide high dimming ratio brightness control with a PWM input signal.

The boost/SEPIC converter has adaptive output voltage control based on the LED current sink headroom voltages. This feature minimizes the power consumption by adjusting the voltage to lowest sufficient level in all conditions. The boost/SEPIC converter supports spread spectrum for switching frequency and an external synchronization with dedicated pin. A wide-range adjustable frequency allows the LP8861-Q1 to avoid disturbance for AM radio band.

The LP8861-Q1 has an option to drive an external p-FET to disconnect the input supply from the system in the event of a fault and reduce inrush current and standby power consumption. The device can reduce LED current based on temperature measured with external NTC sensor to protect LED from overheating and extend LED lifetime.

The input voltage range for the LP8861-Q1 is from 4.5 V to 40 V to support automotive stop/start and load dump condition. The LP8861-Q1 integrates extensive fault detection and protection features.

### Device Information<sup>(1)</sup>

PART NUMBER	PACKAGE	BODY SIZE (NOM)
LP8861-Q1	TSSOP (20)	6.50 mm x 4.50 mm

(1) For all available packages, see the orderable addendum at the end of the data sheet.

### Simplified Schematic

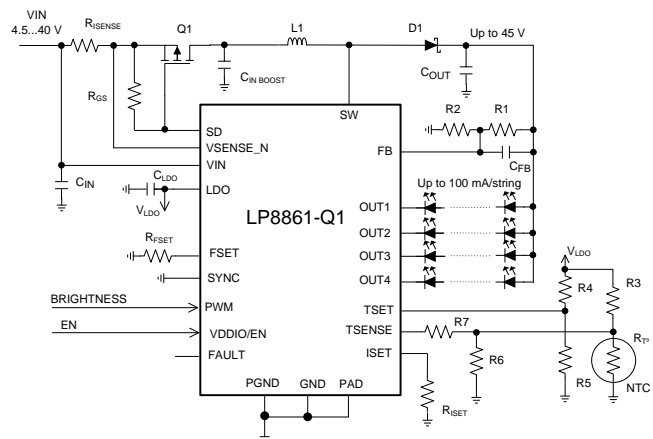

## Table of Contents

<b>1 Features</b> ..... 1 <b>2 Applications</b> ..... 1 <b>3 Description</b> ..... 1 <b>4 Revision History</b> ..... 2 <b>5 Device Comparison Table</b> ..... 3 <b>6 Pin Configuration and Functions</b> ..... 4 <b>7 Specifications</b> ..... 6 7.1 Absolute Maximum Ratings ..... 6 7.2 ESD Ratings ..... 6 7.3 Recommended Operating Conditions ..... 6 7.4 Thermal Information ..... 7 7.5 Electrical Characteristics ..... 7 7.6 Internal LDO Electrical Characteristics ..... 7 7.7 Protection Electrical Characteristics ..... 7 7.8 Power Line FET Control Electrical Characteristics ... 8 7.9 Current Sinks Electrical Characteristics ..... 8 7.10 PWM Brightness Control Electrical Characteristics 8 7.11 Boost/SEPIC Converter Characteristics ..... 8 7.12 Logic Interface Characteristics ..... 9 7.13 Typical Characteristics ..... 10 <b>8 Detailed Description</b> ..... 12	8.1 Overview ..... 12 8.2 Functional Block Diagram ..... 13 8.3 Feature Description ..... 14 8.4 Device Functional Modes ..... 23 <b>9 Application and Implementation</b> ..... 25 9.1 Application Information ..... 25 9.2 Typical Applications ..... 25 <b>10 Power Supply Recommendations</b> ..... 34 <b>11 Layout</b> ..... 34 11.1 Layout Guidelines ..... 34 11.2 Layout Example ..... 35 <b>12 Device and Documentation Support</b> ..... 36 12.1 Device Support ..... 36 12.2 Documentation Support ..... 36 12.3 Receiving Notification of Documentation Updates 36 12.4 Community Resources ..... 36 12.5 Trademarks ..... 36 12.6 Electrostatic Discharge Caution ..... 36 12.7 Glossary ..... 36 <b>13 Mechanical, Packaging, and Orderable Information</b> ..... 36
--	--

## 4 Revision History

NOTE: Page numbers for previous revisions may differ from page numbers in the current version.

Changes from Revision B (April 2017) to Revision C	Page
• Expanded descriptions for pins 3, 8, 9, 10, and 16 in <i>Pin Functions</i> .....	5

Changes from Revision A (November 2015) to Revision B	Page
• Changed "Dimming Ratio of 10 000:1 at 200 Hz" to "Dimming Ratio of 10 000:1 at 100 Hz" .....	1
• Changed some minor wording of <i>Features</i> .....	1
• Added new bulleted items to <i>Applications</i> .....	1
• Changed "controller" to "converter" and "The high switching..." to "A wide-range adjustable..." .....	1
• Added <a href="#">Device Comparison Table</a> table .....	3
• Changed "In synchronization" to "If synchronization" .....	5
• Changes to <a href="#">PWM Brightness Control Electrical Characteristics</a> : delete "I <sub>OUT</sub> = 100 mA. No external load from LDO" from Minimum ON/OFF time test conditions; move "0.5" from MAX to TYP in same row; add footnote 1 .....	8
• Added footnote 1 to <a href="#">Boost/SEPIC Converter Characteristics</a> for Toff, tsync_on_min, and tsync_off_min .....	8
• Deleted "Initial DC-DC voltage is about 88% of V <sub>MAX BOOST</sub> ." from <a href="#">Integrated Boost/SEPIC Converter</a> .....	14
• Changed <a href="#">Equation 1</a> .....	14
• Added definitions for <a href="#">Equation 1</a> .....	14
• Added paragraph after <a href="#">Figure 9</a> .....	14
• Added new paragraph before <a href="#">Internal LDO</a> .....	16
• Deleted "Dimming ratio is calculated as ratio between the input PWM period and minimum on/off time (0.5 μs)." from <a href="#">Brightness Control</a> .....	16
• Changed "less then" to "less than" .....	27

**Changes from Original (August 2015) to Revision A**
**Page**

• Changed maximum $T_{stg}$ from 160°C to 150°C .....	6
• Added last 2 sentences to end of <a href="#">Internal LDO</a> .....	16
• Changed Equation 3 .....	16
• Changed Figure 29 to update VIN and VSENSE_N pin connections; removed RISENSE row from sub-section 8.2.2.1 <i>Design Requirements</i> .....	28

## 5 Device Comparison Table

	LP8860-Q1	LP8862-Q1	LP8861-Q1	TPS61193-Q1	TPS61194-Q1	TPS61196-Q1
VIN range	3 V to 48 V	4.5 V to 45 V	4.5 V to 45 V	4.5 V to 45 V	4.5 V to 45 V	8 V to 30 V
# LED channels	4	2	4	3	4	6
LED current / channel	150 mA	160 mA	100 mA	100 mA	100 mA	200 mA
I2C/SPI support	Yes	No	No	No	No	No
SEPIC support	No	Yes	Yes	Yes	Yes	No

## 6 Pin Configuration and Functions

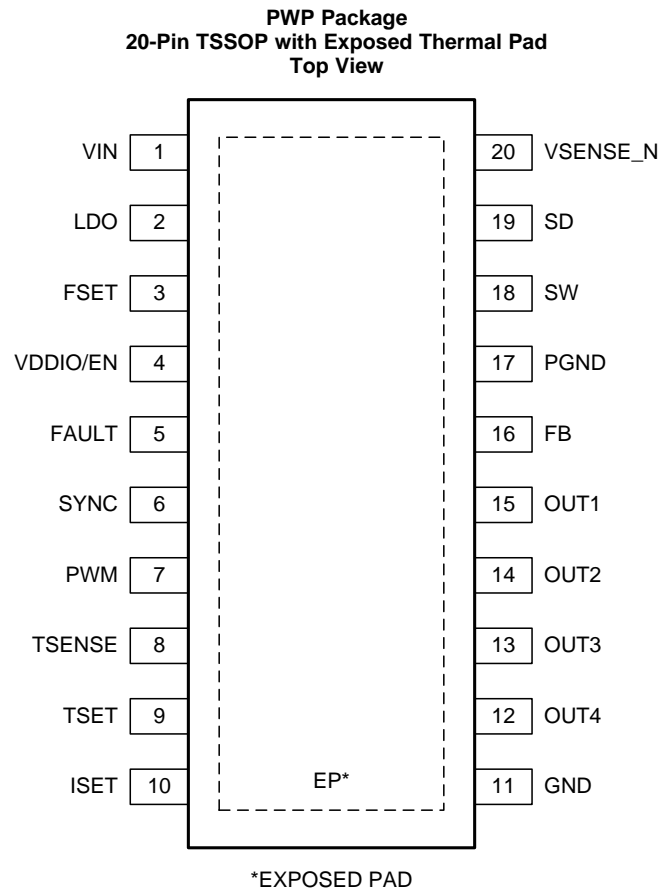

### Pin Functions

PIN		TYPE <sup>(1)</sup>	DESCRIPTION
NUMBER	NAME		
1	VIN	P	Input power pin as well as the positive input for an optional current-sense resistor.
2	LDO	A	Output of internal LDO; connect a 1- $\mu$ F decoupling capacitor between this pin and noise-free ground.
3	FSET	A	Boost/SEPIC switching frequency setting resistor; for normal operation, resistor value from 24 k $\Omega$ to 219 k $\Omega$ must be connected between this pin and ground.
4	VDDIO/EN	I	Enable input for the device as well as supply input (VDDIO) for digital pins
5	FAULT	OD	Fault signal output. If unused, the pin may be left floating.
6	SYNC	I	Input for synchronizing boost/SEPIC. If synchronization is not used, connect this pin to GND to disable spread spectrum or to VDDIO/EN to enable spread spectrum.
7	PWM	I	PWM dimming input.
8	TSENSE	A	Input for NTC bridge. Refer to <a href="#">LED Current Dimming With External Temperature Sensor</a> for proper connection. If unused, the pin must be left floating.
9	TSET	A	Input for NTC bridge. Refer to <a href="#">LED Current Dimming With External Temperature Sensor</a> for proper connection. This pin must be connected to GND if not used.
10	ISET	A	LED current setting resistor; for normal operation, resistor value from 24 k $\Omega$ to 129 k $\Omega$ must be connected between this pin and ground.
11	GND	G	Ground.
12	OUT4	A	Current sink output. This pin must be connected to GND if not used.
13	OUT3	A	Current sink output. This pin must be connected to GND if not used.
14	OUT2	A	Current sink output. This pin must be connected to GND if not used.
15	OUT1	A	Current sink output. This pin must be connected to GND if not used.
16	FB	A	Boost/SEPIC feedback input; for normal operation this pin must be connected to the middle of a resistor divider between V <sub>OUT</sub> and ground using feedback resistor values from 5 k $\Omega$ to 150 k $\Omega$ .
17	PGND	G	Boost/SEPIC power ground.
18	SW	A	Boost/SEPIC switch pin.
19	SD	A	Power-line FET control. If unused, the pin may be left floating.
20	VSENSE_N	A	Input current sense pin. Connect to VIN pin when optional input current sense resistor is not used.

(1) A: Analog pin, G: Ground pin, P: Power pin, I: Input pin, I/O: Input/Output pin, O: Output pin, OD: Open Drain pin

## 7 Specifications

### 7.1 Absolute Maximum Ratings

Over operating free-air temperature range (unless otherwise noted)<sup>(1)(2)</sup>

		MIN	MAX	UNIT
Voltage on pins	VIN, VSENSE_N, SD, SW, FB	-0.3	50	V
	OUT1...OUT4	-0.3	45	
	LDO, SYNC, FSET, ISET, TSENSE, TSET, PWM, VDDIO/EN, FAULT	-0.3	5.5	
Continuous power dissipation <sup>(3)</sup>		Internally Limited		
Ambient temperature range, T <sub>A</sub> <sup>(4)</sup>		-40	125	°C
Junction temperature range, T <sub>J</sub> <sup>(4)</sup>		-40	150	°C
Maximum lead temperature (soldering)			See <sup>(5)</sup>	°C
Storage temperature, T <sub>stg</sub>		-65	150	°C

- (1) Stresses beyond those listed under absolute maximum ratings may cause permanent damage to the device. These are stress ratings only, and functional operation of the device at these or any other conditions beyond those indicated under recommended operating conditions is not implied. Exposure to absolute-maximum-rated conditions for extended periods may affect device reliability.
- (2) All voltages are with respect to the potential at the GND pins.
- (3) Internal thermal shutdown circuitry protects the device from permanent damage. Thermal shutdown engages at T<sub>J</sub> = 165°C (typical) and disengages at T<sub>J</sub> = 145°C (typical).
- (4) In applications where high power dissipation and/or poor package thermal resistance is present, the maximum ambient temperature may have to be derated. Maximum ambient temperature (T<sub>A-MAX</sub>) is dependent on the maximum operating junction temperature (T<sub>J-MAX-OP</sub> = 150°C), the maximum power dissipation of the device in the application (P<sub>D-MAX</sub>), and the junction-to ambient thermal resistance of the part/package in the application (R<sub>θJA</sub>), as given by the following equation: T<sub>A-MAX</sub> = T<sub>J-MAX-OP</sub> - (R<sub>θJA</sub> × P<sub>D-MAX</sub>).
- (5) For detailed soldering specifications and information, refer to the *PowerPAD™ Thermally Enhanced Package Application Note (SLMA002)*.

### 7.2 ESD Ratings

		VALUE	UNIT	
V <sub>(ESD)</sub> Electrostatic discharge	Human-body model (HBM), per AEC Q100-002 <sup>(1)</sup>	±2000	V	
	Charged-device model (CDM), per AEC Q100-011	Other pins		±500
		Corner pins (1,10,11,20)		±750

- (1) AEC Q100-002 indicates that HBM stressing shall be in accordance with the ANSI/ESDA/JEDEC JS-001 specification.

### 7.3 Recommended Operating Conditions

Over operating free-air temperature range (unless otherwise noted)<sup>(1)</sup>

		MIN	MAX	UNIT
Voltage on pins	VIN	4.5	45	V
	VSENSE_N, SD, SW	0	45	
	OUT1...OUT4	0	40	
	FB, FSET, LDO, ISET, TSENSE, TSET, VDDIO/EN, FAULT	0	5.25	
	SYNC, PWM	0	VDDIO/EN	

- (1) All voltages are with respect to the potential at the GND pins.

## 7.4 Thermal Information

THERMAL METRIC <sup>(1)</sup>		LP8861-Q1	UNIT
		PWP (TSSOP)	
		20 PINS	
R <sub>θJA</sub>	Junction-to-ambient thermal resistance <sup>(2)</sup>	44.2	°C/W
R <sub>θJctop</sub>	Junction-to-case (top) thermal resistance	26.5	°C/W
R <sub>θJB</sub>	Junction-to-board thermal resistance	22.4	°C/W
ψ <sub>JT</sub>	Junction-to-top characterization parameter	0.9	°C/W
ψ <sub>JB</sub>	Junction-to-board characterization parameter	22.2	°C/W
R <sub>θJcbot</sub>	Junction-to-case (bottom) thermal resistance	2.5	°C/W

(1) For more information about traditional and new thermal metrics, see the [Semiconductor and IC Package Thermal Metrics](#) application report.

(2) Junction-to-ambient thermal resistance is highly application and board-layout dependent. In applications where high maximum power dissipation exists, special care must be paid to thermal dissipation issues in board design.

## 7.5 Electrical Characteristics

T<sub>J</sub> = -40°C to +125°C (unless otherwise noted)<sup>(1)(2)</sup>

PARAMETER		TEST CONDITIONS	MIN	TYP	MAX	UNIT
I <sub>Q</sub>	Standby supply current	Device disabled, V <sub>VDDIO/EN</sub> = 0 V, V <sub>IN</sub> = 12 V		4.5	20	μA
	Active supply current	V <sub>IN</sub> = 12 V, V <sub>BOOST</sub> = 26 V, output current 80 mA/channel, f <sub>SW</sub> = 300 kHz		5	12	mA
V <sub>POR_R</sub>	Power-on reset rising threshold	LDO pin voltage. Output of the internal LDO or an external supply input (V <sub>DD</sub> ).			2.7	V
V <sub>POR_F</sub>	Power-on reset falling threshold	LDO pin voltage. Output of the internal LDO or an external supply input (V <sub>DD</sub> ).	1.5			V
T <sub>TSD</sub>	Thermal shutdown threshold		150	165	175	°C
T <sub>TSD_THR</sub>	Thermal shutdown hysteresis			20		°C

(1) All voltages are with respect to the potential at the GND pins.

(2) Min and Max limits are specified by design, test, or statistical analysis.

## 7.6 Internal LDO Electrical Characteristics

T<sub>J</sub> = -40°C to +125°C (unless otherwise noted).

PARAMETER		TEST CONDITIONS	MIN	TYP	MAX	UNIT
V <sub>LDO</sub>	Output voltage	V <sub>IN</sub> = 12 V	4.15	4.3	4.45	V
V <sub>DR</sub>	Dropout voltage	External current load 5 mA	120	220	430	mV
I <sub>SHORT</sub>	Short circuit current			50		mA
I <sub>EXT_MAX</sub>	Maximum current for external load			5		mA

## 7.7 Protection Electrical Characteristics

T<sub>J</sub> = -40°C to +125°C (unless otherwise noted).

PARAMETER		TEST CONDITIONS	MIN	TYP	MAX	UNIT
V <sub>OVP</sub>	VIN OVP threshold voltage		41	42	44	V
I <sub>OCP</sub>	VIN OCP current	R <sub>SENSE</sub> = 50 mΩ	2.7	3.2	3.7	A
V <sub>UVLO</sub>	VIN UVLO			4.0		V
V <sub>UVLO_HYST</sub>	VIN UVLO hysteresis			100		mV
	LED short detection threshold		5.6	6	7	V

## 7.8 Power Line FET Control Electrical Characteristics

 $T_J = -40^{\circ}\text{C}$  to  $+125^{\circ}\text{C}$  (unless otherwise noted).

PARAMETER	TEST CONDITIONS	MIN	TYP	MAX	UNIT
VSENSE_N pin leakage current	$V_{\text{VSENSE\_N}} = 45\text{ V}$		0.1	3	$\mu\text{A}$
SD leakage current	$V_{\text{SD}} = 45\text{ V}$		0.1	3	$\mu\text{A}$
SD pulldown current		185	230	283	$\mu\text{A}$

## 7.9 Current Sinks Electrical Characteristics

 $T_J = -40^{\circ}\text{C}$  to  $+125^{\circ}\text{C}$  (unless otherwise noted).

PARAMETER	TEST CONDITIONS	MIN	TYP	MAX	UNIT
$I_{\text{LEAKAGE}}$ Leakage current	Outputs OUT1 to OUT4, $V_{\text{OUTx}} = 45\text{ V}$		0.1	5	$\mu\text{A}$
$I_{\text{MAX}}$ Maximum current	OUT1 to OUT4		100		mA
$I_{\text{OUT}}$ Output current accuracy	$I_{\text{OUT}} = 100\text{ mA}$	-5%		5%	
$I_{\text{MATCH}}$ Output current matching <sup>(1)</sup>	$I_{\text{OUT}} = 100\text{ mA}$ , PWM duty = 100%		1%	3.5%	
$V_{\text{SAT}}$ Saturation voltage <sup>(2)</sup>	$I_{\text{OUT}} = 100\text{ mA}$ , $V_{\text{LDO}} = 4.3\text{ V}$		0.4	0.7	V

- (1) Output Current Accuracy is the difference between the actual value of the output current and programmed value of this current. Matching is the maximum difference from the average. For the constant current sinks on the part (OUT1 to OUT4), the following are determined: the maximum output current (MAX), the minimum output current (MIN), and the average output current of all outputs (AVG). Matching number is calculated:  $(\text{MAX}-\text{MIN})/\text{AVG}$ . The typical specification provided is the most likely norm of the matching figure for all parts. LED current sinks were characterized with 1-V headroom voltage. Note that some manufacturers have different definitions in use.
- (2) Saturation voltage is defined as the voltage when the LED current has dropped 10% from the value measured at 1 V.

## 7.10 PWM Brightness Control Electrical Characteristics

 $T_J = -40^{\circ}\text{C}$  to  $+125^{\circ}\text{C}$  (unless otherwise noted).

PARAMETER	TEST CONDITIONS	MIN	TYP	MAX	UNIT
$f_{\text{PWM}}$ Recommended PWM input frequency		100		20 000	Hz
$t_{\text{ON/OFF}}$ Minimum ON/OFF time <sup>(1)</sup>			0.5		$\mu\text{s}$

- (1) This specification is not ensured by ATE.

## 7.11 Boost/SEPIC Converter Characteristics

 $T_J = -40^{\circ}\text{C}$  to  $+125^{\circ}\text{C}$  (unless otherwise noted).

Unless otherwise specified:  $V_{\text{IN}} = 12\text{ V}$ ,  $V_{\text{VDDIO/EN}} = 3.3\text{ V}$ ,  $L = 22\text{ }\mu\text{H}$ ,  $C_{\text{IN}} = 2 \times 10\text{-}\mu\text{F}$  ceramic and  $33\text{-}\mu\text{F}$  electrolytic,  $C_{\text{OUT}} = 2 \times 10\text{-}\mu\text{F}$  ceramic and  $33\text{-}\mu\text{F}$  electrolytic,  $D = \text{NRVB460MFS}$ ,  $f_{\text{SW}} = 300\text{ kHz}$ .

PARAMETER	TEST CONDITIONS	MIN	TYP	MAX	UNIT
$V_{\text{IN}}$ Input voltage		4.5		40	V
$V_{\text{OUT}}$ Output voltage		10		45	V
$f_{\text{SW\_MIN}}$ Minimum switching frequency (central frequency if spread spectrum is enabled)	Defined by $R_{\text{FSET}}$ resistor		300		kHz
$f_{\text{SW\_MAX}}$ Maximum switching frequency (central frequency if spread spectrum is enabled)			2200		kHz
$V_{\text{OUT}}/V_{\text{IN}}$ Conversion ratio				10	
$T_{\text{OFF}}$ Minimum switch OFF time <sup>(1)</sup>	$f_{\text{SW}} \geq 1.15\text{ MHz}$			55	ns
$I_{\text{SW\_MAX}}$ SW current limit		1.8	2	2.2	A
$R_{\text{DSon}}$ FET $R_{\text{DSon}}$	Pin-to-pin		240	400	$\text{m}\Omega$
$f_{\text{SYNC}}$ External SYNC frequency		300		2200	kHz
$t_{\text{SYNC\_ON\_MIN}}$ External SYNC minimum ON time <sup>(1)</sup>			150		ns
$t_{\text{SYNC\_OFF\_MIN}}$ External SYNC minimum OFF time <sup>(1)</sup>			150		ns

- (1) This specification is not ensured by ATE.

## 7.12 Logic Interface Characteristics

$T_J = -40^{\circ}\text{C}$  to  $+125^{\circ}\text{C}$  (unless otherwise noted).

PARAMETER		TEST CONDITIONS	MIN	TYP	MAX	UNIT
<b>LOGIC INPUT VDDIO/EN</b>						
$V_{IL}$	Input low level				0.4	V
$V_{IH}$	Input high level		1.65			V
$I_i$	Input current		-1	5	30	$\mu\text{A}$
<b>LOGIC INPUTS SYNC, PWM</b>						
$V_{IL}$	Input low level				$0.2 \times V_{VDDIO/EN}$	V
$V_{IH}$	Input high level		$0.8 \times V_{VDDIO/EN}$			
$I_i$	Input current		-1		1	$\mu\text{A}$
<b>LOGIC OUTPUT FAULT</b>						
$V_{OL}$	Output low level	Pullup current 3 mA		0.3	0.5	V
$I_{LEAKAGE}$	Output leakage current	$V = 5.5\text{ V}$			1	$\mu\text{A}$

### 7.13 Typical Characteristics

Unless otherwise specified: D = NRVB460MFS, T = 25°C.

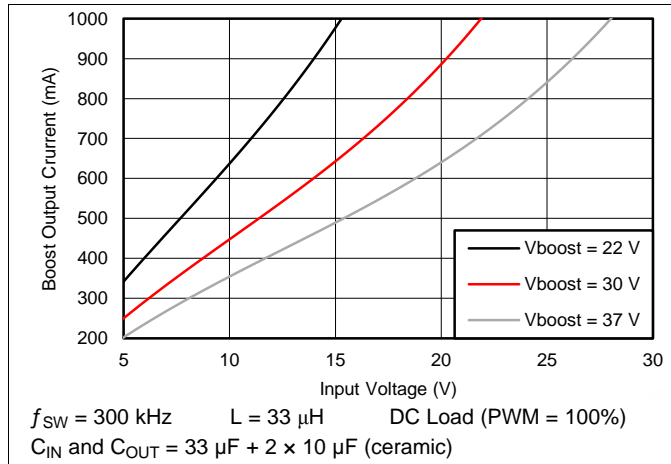

Figure 1. Maximum Boost Output Current

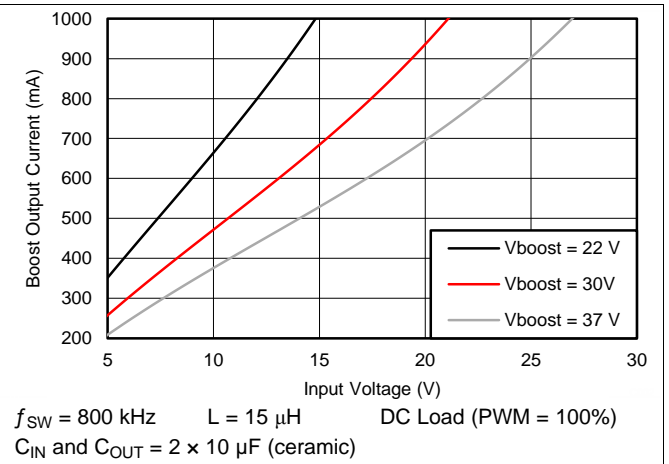

Figure 2. Maximum Boost Output Current

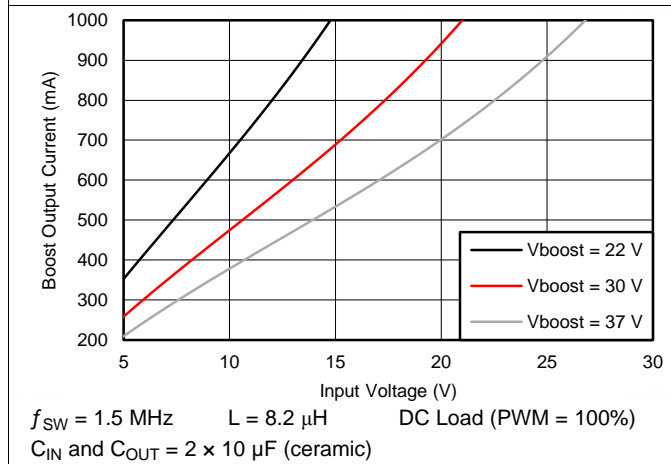

Figure 3. Maximum Boost Output Current

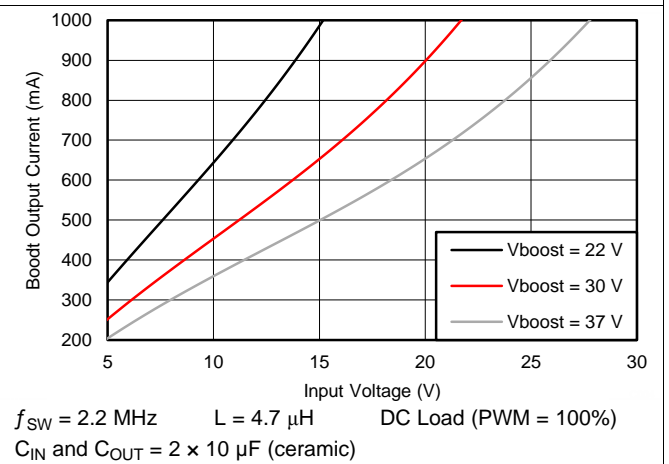

Figure 4. Maximum Boost Output Current

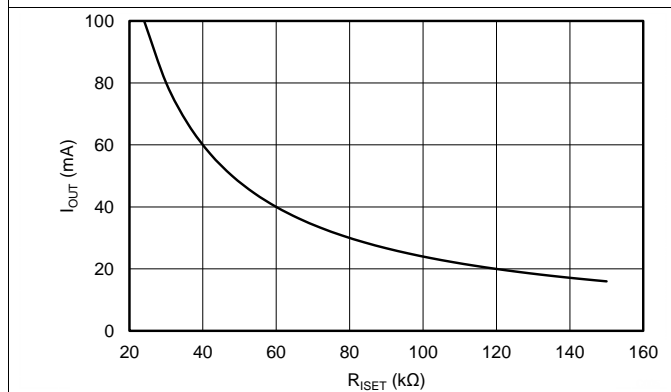

Figure 5. LED Current vs  $R_{ISET}$

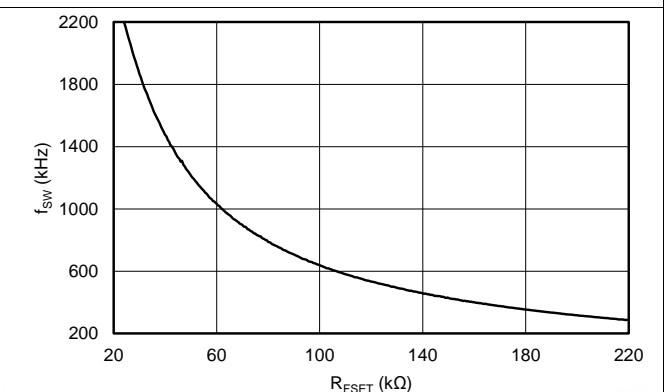
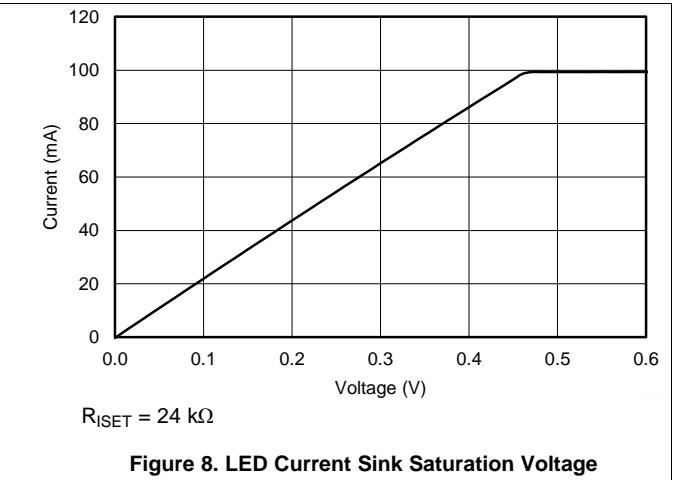
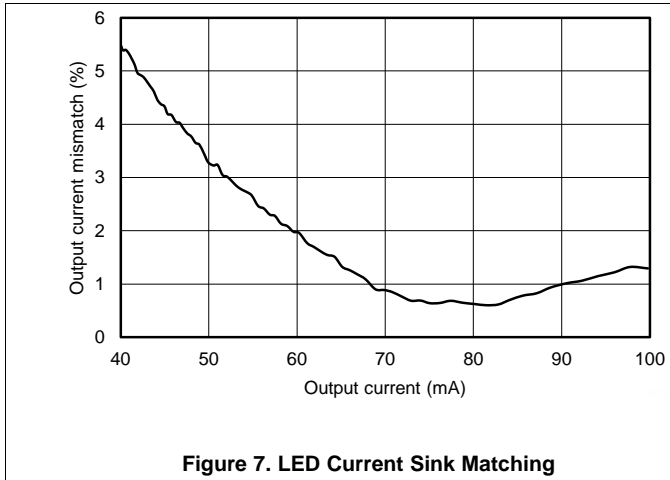

Figure 6. Boost Switching Frequency  $f_{SW}$  vs  $R_{FSET}$

**Typical Characteristics (continued)**

Unless otherwise specified: D = NRVB460MFS, T = 25°C.



## 8 Detailed Description

### 8.1 Overview

The LP8861-Q1 is a highly integrated LED driver for automotive infotainment, lighting systems, and medium-sized LCD backlight applications. It includes a boost/SEPIC converter with an integrated FET, an internal LDO, and four LED current sinks. A VDDIO/EN pin provides the supply voltage for digital IOs (PWM and SYNC inputs) and at the same time enables the device.

The switching frequency on the boost/SEPIC regulator is set by a resistor connected to the FSET pin. The maximum voltage is set by a resistive divider connected to the FB pin. For the best efficiency the voltage is adapted automatically to the minimum necessary level needed to drive the LED strings. This is done by monitoring LED output voltage in real time. For EMI reduction and control two optional features are available:

- Spread spectrum, which reduces EMI noise spikes at the switching frequency and its harmonic frequencies.
- Boost/SEPIC can be synchronized to an external clock frequency connected to the SYNC pin.

The four constant current sinks for driving the LEDs provide current up to 100 mA per sink and can be tied together to get a higher current. Value for the current value is set with a resistor connected to the ISET pin. Current sinks that are not used must be connected to the ground. Grounded current sinks are disabled and excluded from the adaptive voltage and open/short LED fault detection loop.

Brightness is controlled with the PWM input. Frequency range for the input PWM is from 100 Hz to 20 kHz. LED output PWM follows the input PWM so the output frequency is equal to the input frequency.

The LP8861-Q1 has extensive fault detection features:

- Open-string and shorted LED detections
  - LED fault detection prevents system overheating in case of open or short in some of the LED strings
- $V_{IN}$  input-overvoltage protection
  - Threshold sensing from VIN pin
- $V_{IN}$  input undervoltage protection
  - Threshold sensing from VIN pin
- $V_{IN}$  input overcurrent protection
  - Threshold sensing across  $R_{ISENSE}$  resistor
- Thermal shutdown in case of die overtemperature
- LED thermal protection with a external NTC (optional feature)

Fault condition is indicated with the FAULT output pin. Additionally, the LP8861-Q1 supports control for an optional power-line FET allowing further protection in boost/SEPIC overcurrent state by disconnecting the device from power-line in fault condition. With the power-line FET control it is possible to protect device, boost components, and LEDs in case of shorted  $V_{BOOST}$  and too-high  $V_{IN}$  voltage. Power-line FET control also features soft-start which reduces the peak current from the power line during start-up.

## 8.2 Functional Block Diagram

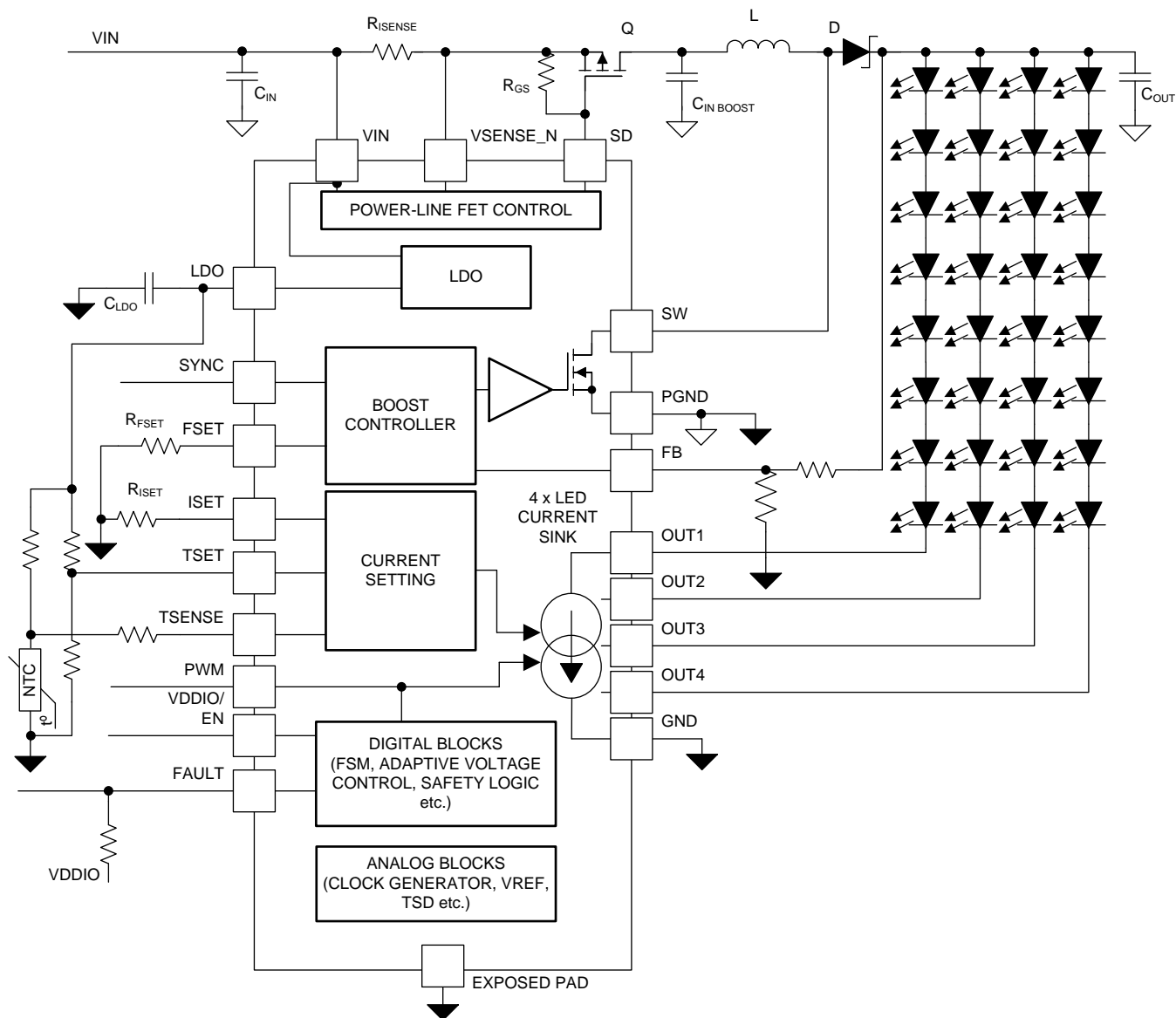

## 8.3 Feature Description

### 8.3.1 Integrated Boost/SEPIC Converter

The LP8861-Q1 boost/SEPIC DC-DC converter generates supply voltage for the LEDs. The maximum output voltage  $V_{MAX\ BOOST}$  is defined by an external resistive divider (R1, R2).

Maximum voltage must be chosen based on the maximum voltage required for LED strings. Recommended  $V_{MAX\ BOOST}$  is about 30% higher than maximum LED string voltage. DC-DC output voltage is adjusted automatically based on LED current sink headroom voltage. Maximum, minimum, and initial boost voltages can be calculated with [Equation 1](#):

$$V_{BOOST} = \left( \frac{V_{BG}}{R2} + K \times 0.0387 \right) \times R1 + V_{BG}$$

where

- $V_{BG} = 1.2\text{ V}$
- R2 recommended value is 130 k $\Omega$
- Resistor values are in k $\Omega$
- $K = 1$  for maximum adaptive boost voltage (typical)
- $K = 0$  for minimum adaptive boost voltage (typical)
- $K = 0.88$  for initial boost voltage (typical)

(1)

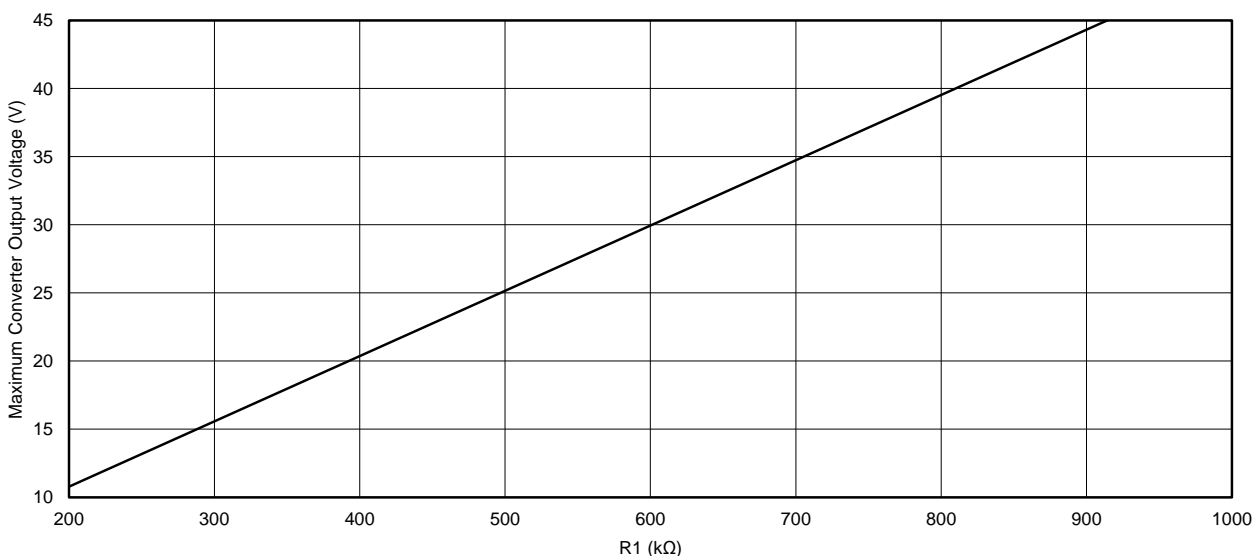

**Figure 9. Maximum Converter Output Voltage vs R1 Resistance**

Alternatively, a T-divider can be used if resistance less than 100 k $\Omega$  is required for the external resistive divider. Refer to [LP8861-Q1EVM Evaluation Module](#) for details.

The converter is a current mode DC-DC converter, where the inductor current is measured and controlled with the feedback. Switching frequency is adjustable between 300 kHz and 2.2 MHz with  $R_{FSET}$  resistor as shown in [Equation 2](#):

$$f_{SW} = 67600 / (R_{FSET} + 6.4)$$

where

- $f_{SW}$  is switching frequency, kHz
- $R_{FSET}$  is frequency setting resistor, k $\Omega$

(2)

**Feature Description (continued)**

In most cases lower frequency has higher system efficiency. Boost parameters are chosen automatically during start-up according to the selected switching frequency (see Table 2). In boost mode a 15-pF capacitor  $C_{FB}$  must be placed across resistor R1 when operating in 300 kHz ... 500 kHz range (see Figure 24). When operating in the 1.8-MHz...2.2-MHz range,  $C_{FB} = 4.7$  pF (see Figure 29).

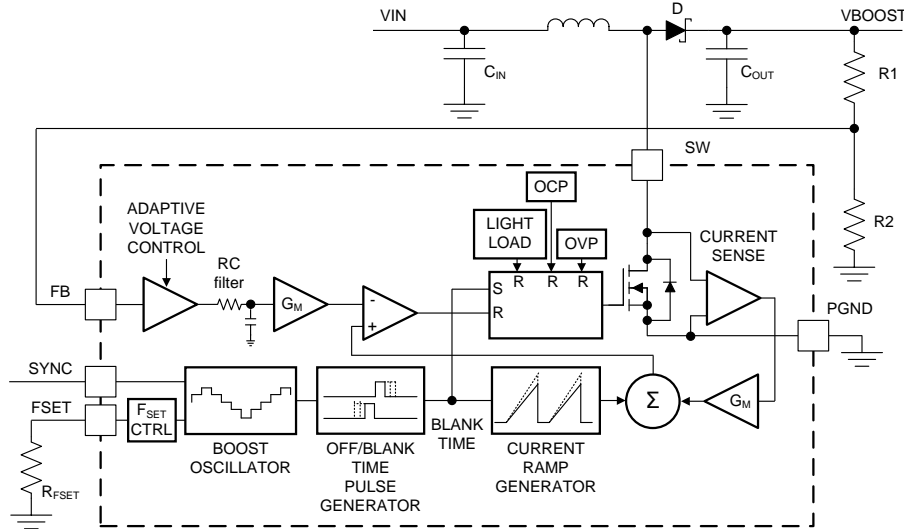

**Figure 10. Boost Block Diagram**

Boost clock can be driven by an external SYNC signal between 300 kHz...2.2 MHz. If the external synchronization input disappears, boost continues operation at the frequency defined by the  $R_{FSET}$  resistor. When external frequency disappears and SYNC pin level is low, boost continues operation without spread spectrum immediately. If SYNC remains high, boost continues switching with spread spectrum enabled after 256  $\mu$ s.

External SYNC frequency must be 1.2...1.5 times higher than the frequency defined by the  $R_{FSET}$  resistor. Minimum frequency setting with  $R_{FSET}$  is 250 kHz to support minimum switching frequency with external clock frequency 300 kHz.

The optional spread-spectrum feature ( $\pm 3\%$  from central frequency, 1-kHz modulation frequency) reduces EMI noise spikes at the switching frequency and its harmonic frequencies. When external synchronization is used, spread spectrum is not available.

**Table 1. Boost Synchronization Mode**

SYNC PIN STATUS	MODE
Low	Spread spectrum disabled
High	Spread spectrum enabled
300...2200 kHz frequency	Spread spectrum disabled, external synchronization mode

**Table 2. Boost Parameters<sup>(1)</sup>**

RANGE	FREQUENCY (kHz)	TYPICAL INDUCTANCE (μH)	TYPICAL BOOST INPUT AND OUTPUT CAPACITORS (μF)	MIN SWITCH OFF TIME (ns) <sup>(2)</sup>	BLANK TIME (ns)	CURRENT RAMP (A/s)	CURRENT RAMP DELAY (ns)
1	300...480	33	2 × 10 (cer.) + 33 (electr.)	150	95	24	550
2	480...1150	15	10 (cer.) + 33 (electr.)	60	95	43	300
3	1150...1650	10	3 × 10 (cer.)	40	95	79	0
4	1650...2200	4.7	3 × 10 (cer.)	40	70	145	0

(1) Parameters are for reference only.

(2) Due to current sensing comparator delay the actual minimum off time is 6 ns (typical) longer than in the table.

Boost SW pin DC current is limited to 2 A (typical). To support warm start transient condition the current limit is automatically increased to 2.5 A for a short period of 1.5 seconds when a 2-A limit is reached.

#### NOTE

Application condition where the 2-A limit is exceeded continuously is not allowed. In this case the current limit would be 2 A for 1.5 seconds followed by 2.5-A limit for 1.5 seconds, and this 3-second period repeats.

To keep switching voltage within safe levels there is a 48-V limit comparator in the event that FB loop is broken.

### 8.3.2 Internal LDO

The internal LDO regulator converts the input voltage at  $V_{IN}$  to a 4.3-V output voltage. The LDO regulator supplies internal and external circuitry. The maximum external load is 5 mA. Connect LDO output with a minimum of 1-μF ceramic capacitor to ground as close to the LDO pin as possible. If an external voltage higher than 4.5 V is connected to LDO pin, the internal LDO is disabled, and the internal circuitry is powered from the external power supply. VIN and VSENSE\_N pins must be connected to the same external voltage as LDO pin. See [Figure 29](#) for application schematic example.

### 8.3.3 LED Current Sinks

#### 8.3.3.1 Current Sink Configuration

The LP8861-Q1 detects LED current sinks configuration during start-up. Any sink connected to the ground is disabled and excluded from the adaptive boost control and fault detection.

#### 8.3.3.2 Current Setting

Maximum current for the LED current sinks is controlled with external  $R_{ISET}$  resistor.  $R_{ISET}$  value for target maximum current can be calculated using [Equation 3](#):

$$R_{ISET} = 2342 / (I_{OUT} - 2.5)$$

where

- $R_{ISET}$  is current setting resistor, kΩ
  - $I_{OUT}$  is output current per output, mA
- (3)

#### 8.3.3.3 Brightness Control

The LP8861-Q1 controls the brightness of the display with conventional PWM. Output PWM directly follows the input PWM. Input PWM frequency can be in the range of 100 Hz to 20 kHz.

### 8.3.4 Power-Line FET Control

The LP8861-Q1 has a control pin (SD) for driving the gate of an external power-line FET. Power-line FET is an optional feature; an example schematic is shown in [Figure 24](#). Power-line FET limits inrush current by turning on gradually when the device is enabled ( $VDDIO/EN = \text{high}$ ,  $V_{IN} > V_{GS}$ ). Inrush current is controlled by increasing sink current for the FET gradually to 230 μA.

In shutdown the LP8861-Q1 turns off the power-line FET and prevents the possible boost and LEDs leakage. The power switch also turns off in case of any fault which causes the device to enter FAULT RECOVERY state.

### 8.3.5 LED Current Dimming With External Temperature Sensor

The LP8861-Q1 has an optional feature to decrease automatically LED current when LED overheating is detected with an external NTC sensor. An example of the behavior is shown in Figure 11. When the NTC temperature reaches T1, the LP8861-Q1 starts to decrease the LED current. When the LED current has reduced to 17.5% of the nominal value, current turns off until temperature returns to the operation range. When TSET pin is grounded this feature is disabled. Temperature T1 and de-rate slope are defined by external resistors as explained below.

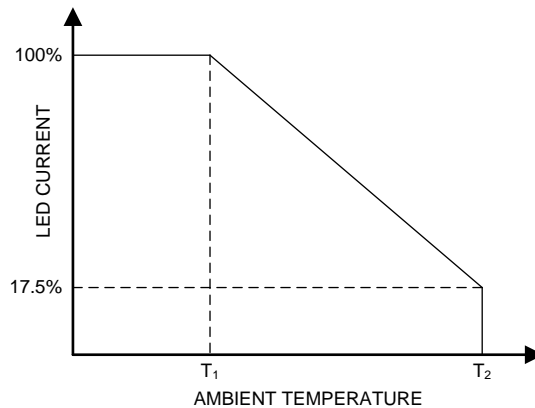

Figure 11. Temperature-Based LED Current Dimming Functionality

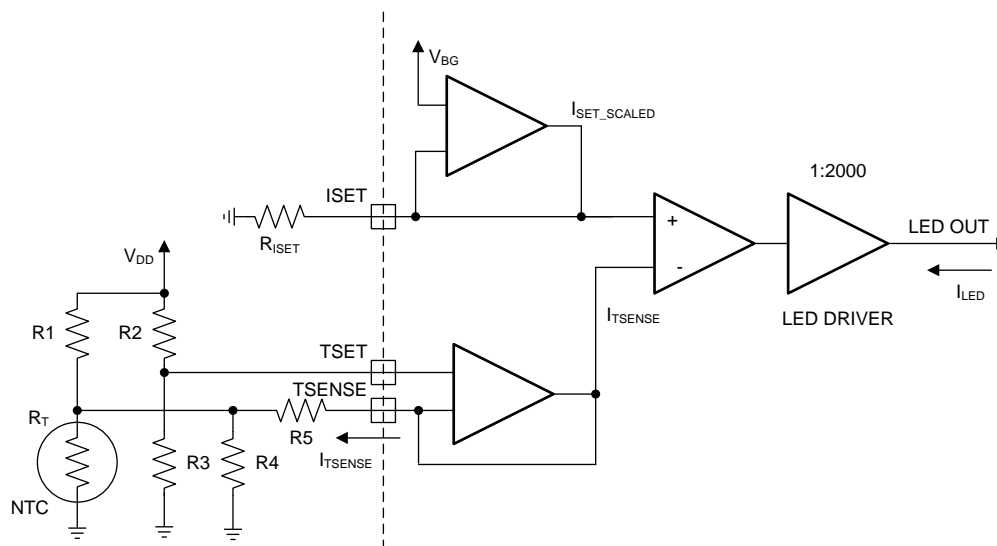

Figure 12. Temperature-Based LED Current Dimming Implementation

When the TSET pin is grounded LED current is set by  $R_{ISET}$  resistor:

$$R_{ISET} = 2342 / (I_{OUT} - 2.5) \quad (4)$$

When external NTC is connected, the TSENSE pin current decreases LED output current. The following steps describe how to calculate LED output current.

Parallel resistance of the NTC sensor  $R_T$  and resistor  $R_4$  is calculated by formula:

$$R_{||} = \frac{R_T \times R_4}{R_T + R_4} \quad (5)$$

TSET voltage can be calculated with Equation 6:

$$V_{TSET} = V_{DD} \times \frac{R3}{R2 + R3} \tag{6}$$

TSENSE pin current is calculated by Equation 7:

$$I_{TSENSE} = \frac{V_{TSET} - V_{DD} \times \frac{R_{II}}{R_{II} + R1}}{R_{II} + R5 - \frac{R_{II}^2}{R_{II} + R1}} \tag{7}$$

ISET pin current defined by R<sub>ISET</sub> is:

$$I_{SET\_SCALED} = \frac{V_{BG}}{R_{ISET}} \tag{8}$$

For Equation 9, I<sub>TSENSE</sub> current must be limited between 0 and I<sub>SET\_SCALED</sub>. If I<sub>TSENSE</sub> > I<sub>SET\_SCALED</sub> then set I<sub>TSENSE</sub> = I<sub>SET\_SCALED</sub>. If I<sub>TSENSE</sub> < 0 then set I<sub>TSENSE</sub> = 0.

LED driver output current is:

$$I_{LED} = (I_{SET\_SCALED} - I_{TSENSE}) \times 2000 \tag{9}$$

When current is lower than 17.5% of the nominal value, the current is set to 0 (so called cut-off point).

An Excel<sup>®</sup> calculator is available for calculating the component values for a specific NTC and target thermal profile (contact your local TI representative). Figure 13 shows an example thermal profile implementation.

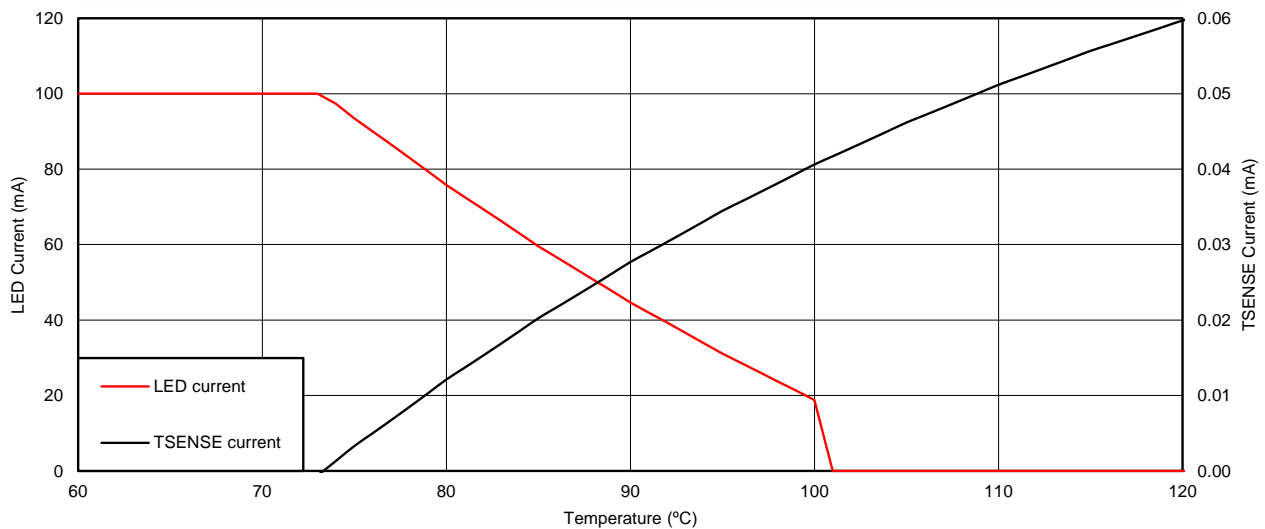

NTC – 10 kΩ at 25°C	R <sub>ISET</sub> = 24 kΩ	R2 = 10 kΩ	R4 = 100 kΩ
VDD = 4.3 V	R1 = 10 kΩ	R3 = 2 kΩ	R5 = 7.5 kΩ

Figure 13. Calculation Example

### 8.3.6 Protection and Fault Detection

The LP8861-Q1 has fault detection for LED open and short, VIN input overvoltage (VIN\_OVP), VIN undervoltage lockout (VIN\_UVLO), power line overcurrent (VIN\_OCP), and thermal shutdown (TSD).

### 8.3.6.1 Adaptive Boost Control and Functionality of LED Fault Comparators

Adaptive boost control function adjusts the boost output voltage to the minimum sufficient voltage for proper LED current sink operation. The output with highest  $V_F$  LED string is detected and boost output voltage adjusted accordingly. Boost adaptive control voltage step size is defined by maximum boost voltage settings,  $V_{STEP} = (V_{MAX\ BOOST} - V_{MIN\ BOOST}) / 256$ . Periodic down pressure is applied to the target boost voltage to achieve better system efficiency.

Every LED current sink has 3 comparators for an adaptive boost control and fault detection. Comparator outputs are filtered, filtering time is 1  $\mu$ s.

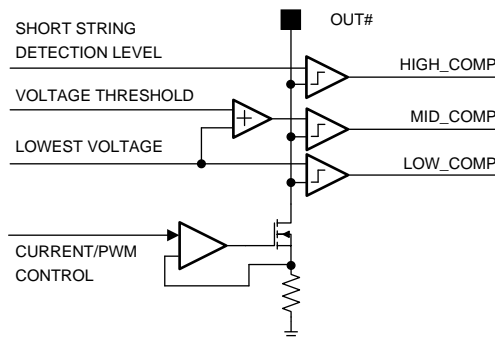

Figure 14. Comparators for Adaptive Voltage Control and LED Fault Detection

Figure 15 illustrates different cases which cause boost voltage increase, decrease, or generate faults. In normal operation, voltage at all the OUT# pins is between LOW\_COMP and MID\_COMP levels and boost voltage stays constant. LOW\_COMP level is the minimum for proper LED current sink operation,  $1.1 \times V_{SAT} + 0.2$  V (typical). MID\_COMP level is  $1.1 \times V_{SAT} + 1.2$  V (typical) — that is, typical headroom window is 1 V.

When voltage at all the OUT# pins increases above MID\_COMP level, boost voltage adapts downwards.

When voltage at any of the OUT# pins falls below LOW\_COMP threshold, boost voltage adapts upwards. In the condition where boost voltage reaches the maximum and there are one or more outputs still below LOW\_COMP level, an open LED fault is detected.

HIGH\_COMP level, 6 V typical, is the threshold for shorted LED detection. When the voltage of one or more of the OUT# pins increases above HIGH\_COMP level and at least one of the other outputs is within the normal headroom window, shorted LED fault is detected.

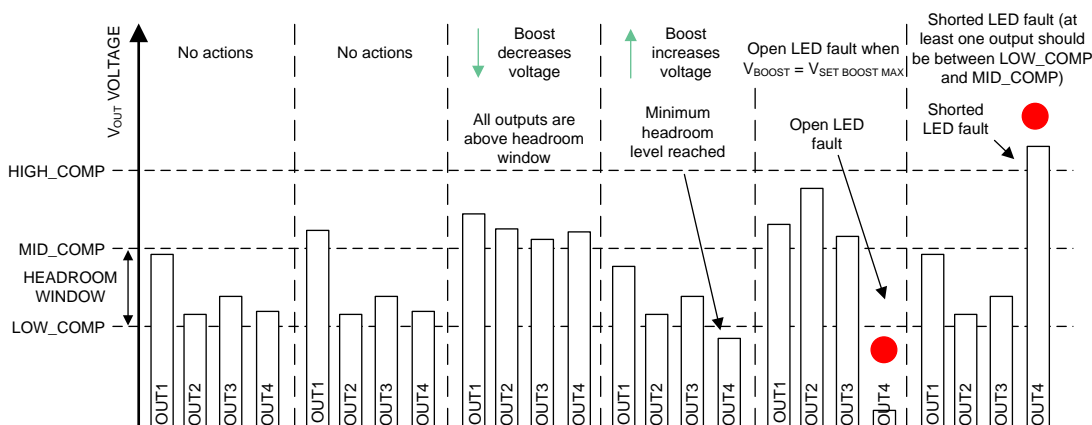

Figure 15. Boost Adaptation and LED Protection Algorithms

### 8.3.6.2 Overview of the Fault/Protection Schemes

The LP8861-Q1 fault detection behavior is described in [Table 3](#). Detected faults (excluding LED faults) cause the device to enter FAULT\_RECOVERY state. In FAULT\_RECOVERY the boost and LED outputs of LP8861-Q1 are disabled, power-line FET is turned off, and the FAULT pin is pulled low. Device recovers automatically and enters normal operating mode (ACTIVE) after a recovery time of 100 ms if the fault condition has disappeared. When recovery is successful, the FAULT pin is released.

In case a LED fault is detected, device continues normal operation and only the faulty string is disabled. Fault is indicated via FAULT pin which can be released by toggling VDDIO/EN pin low for a short period of 2...20  $\mu$ s. LEDs are turned off for this period but device stays in ACTIVE mode. If VDDIO/EN is low longer, device goes to STANDBY and restarts when EN goes high again.

**Table 3. Fault/Protection Schemes**

FAULT/ PROTECTION	FAULT NAME	THRESHOLD	CONNECTED TO FAULT PIN	FAULT_RECOVERY STATE	ACTION
VIN overvoltage protection	VIN_OVP	1. $V_{IN} > 42$ V 2. $V_{BOOST} > V_{SET\_BOOST} + (6...10)$ V $V_{SET\_BOOST}$ is voltage value defined by logic during adaptation	Yes	Yes	1. Overvoltage is monitored from the beginning of soft start. Fault is detected if the duration of overvoltage condition is 100 $\mu$ s minimum. 2. Overvoltage is monitored from the beginning of normal operation (ACTIVE mode). Fault is detected if overvoltage condition duration is 560 ms minimum ( $t_{filter}$ ). After the first fault detection filter time is reduced to 50 ms for following recovery cycles. When device recovers and has been in ACTIVE mode for 160 ms, filter is increased back to 560 ms.
VIN undervoltage lockout	VIN_UVLO	Falling 3.9 V Rising 4 V	Yes	Yes	Detects undervoltage condition at VIN pin. Sensed from the beginning of soft start. Fault is detected if undervoltage condition duration is 100 $\mu$ s minimum.
VIN overcurrent protection	VIN_OCP	3 A (50-m $\Omega$ current sensor resistor)	Yes	Yes	Detects overcurrent by measuring voltage of the SENSE resistor connected between VIN and VSENSE_N pins. Sensed from the beginning of soft start. Fault is detected if undervoltage condition duration is 10 $\mu$ s minimum.
Open LED fault	OPEN_LED	LOW_COMP threshold	Yes	No	Detected if one or more outputs are below threshold level, and boost adaptive control has reached maximum voltage. Open string(s) is removed from voltage control loop and PWM is disabled. Fault pin is cleaned by toggling VDDIO/EN pin. If VDDIO/EN is low for a short period of 2...20 $\mu$ s, LEDs are turned off for this period but device stays ACTIVE. If VDDIO/EN is low longer, device goes to STANDBY and restarts when EN goes high again.
Shorted LED fault	SHORT_LED	Shorted string detection level 6 V	Yes	No	Detected if one or more outputs voltages are above shorted string detection level and at least one LED output voltage is within headroom window. Shorted string(s) are removed from the boost voltage control loop and outputs PWM(s) are disabled. Fault pin is cleaned by toggling VDDIO/EN pin. If VDDIO/EN is low for a short period of 2...20 $\mu$ s, LEDs are turned off for this period but device stays ACTIVE. If VDDIO/EN is low longer, device goes to STANDBY and restarts when EN goes high again.
Thermal protection	TSD	165°C Thermal Shutdown Hysteresis 20°C	Yes	Yes	Thermal shutdown is monitored from the beginning of soft start. Die temperature must decrease by 20°C for device to recover.

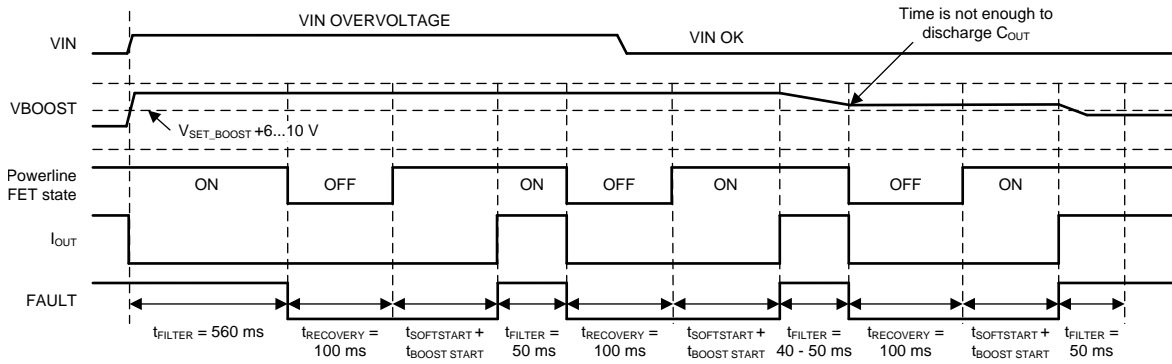

Figure 16. VIN Overvoltage Protection (Boost OVP)

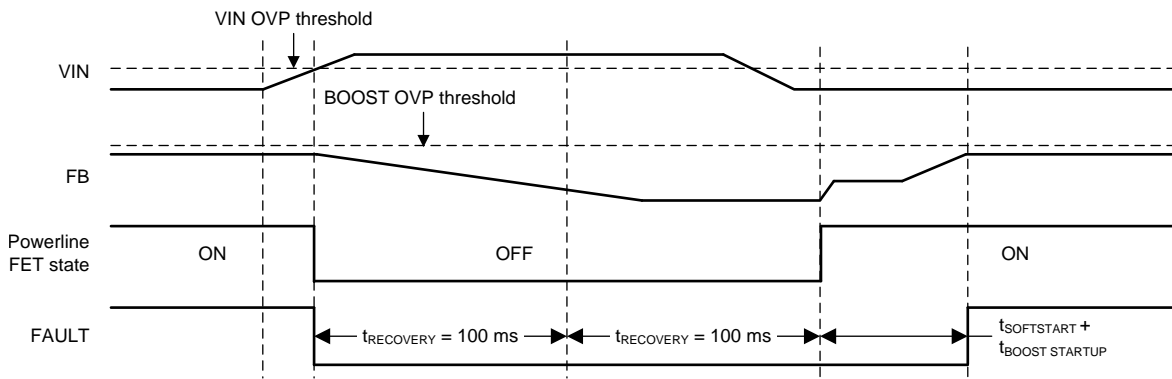

Figure 17. VIN Overvoltage Protection (VIN OVP)

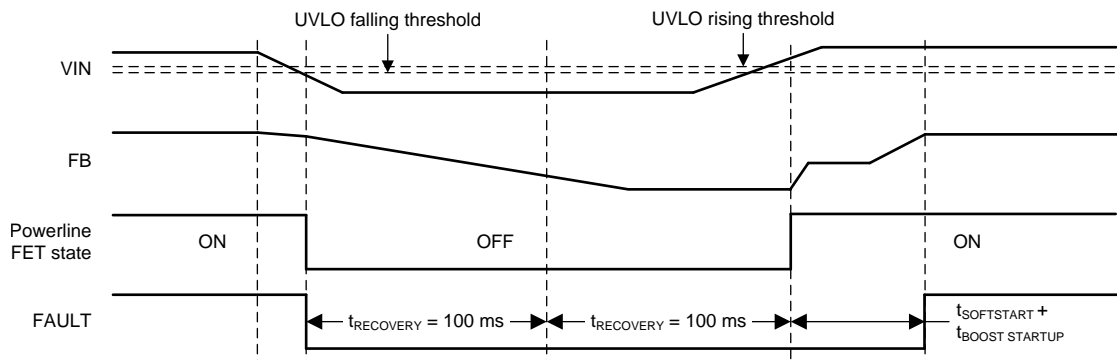

Figure 18. VIN Undervoltage Lockout

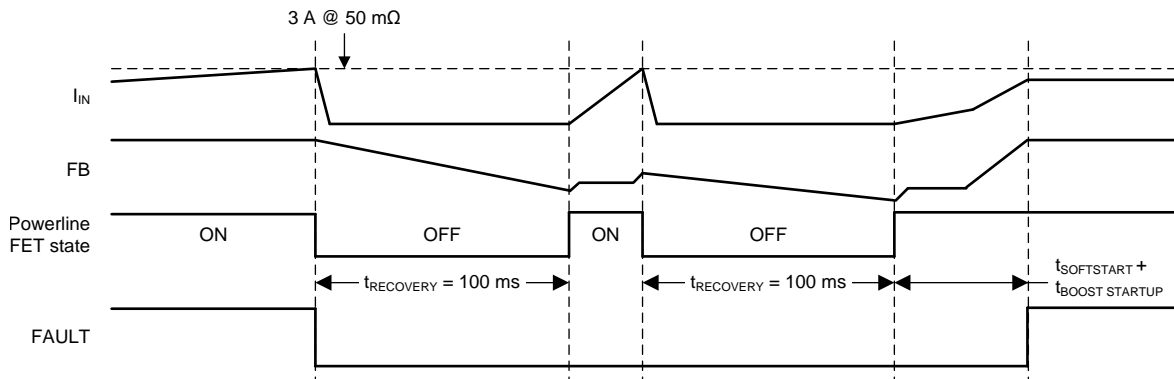

Figure 19. Input Voltage Overcurrent Protection

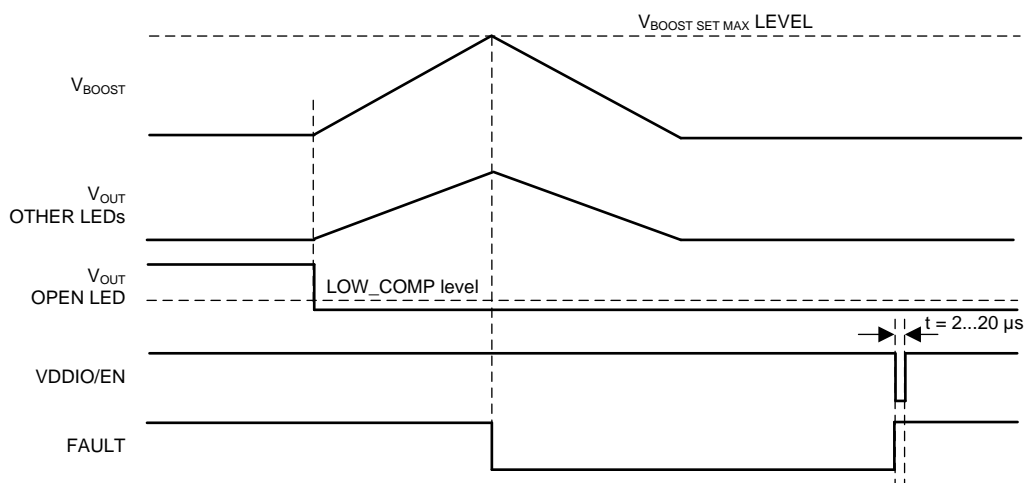

Figure 20. LED Open Fault

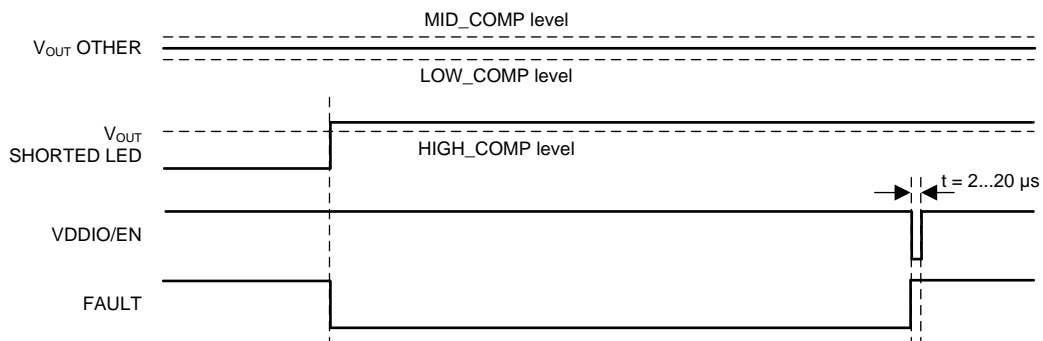

Figure 21. LED Short Fault

## 8.4 Device Functional Modes

### 8.4.1 Device States

The LP8861-Q1 enters STANDBY mode when the internal LDO output rises above the power-on reset level,  $V_{LDO} > V_{POR\_R}$ . In STANDBY mode device is able to detect the VDDIO/EN signal. When VDDIO/EN is pulled high, device powers up. During soft start the external power line FET is opened gradually to limit inrush current. Soft start is followed by boost start, during which time boost voltage is ramped to the initial value. After boost start LED outputs are sensed to detect grounded current sinks. Grounded current sinks are disabled and excluded from the boost voltage control loop.

If a fault condition is detected, the LP8861-Q1 enters FAULT\_RECOVERY state. In this state power line FET is switched off and both the boost and LED current sinks are disabled. Faults that cause the device to enter FAULT\_RECOVERY are listed in Figure 22. When LED open or short is detected, faulty string is disabled but LP8861-Q1 stays in ACTIVE mode.

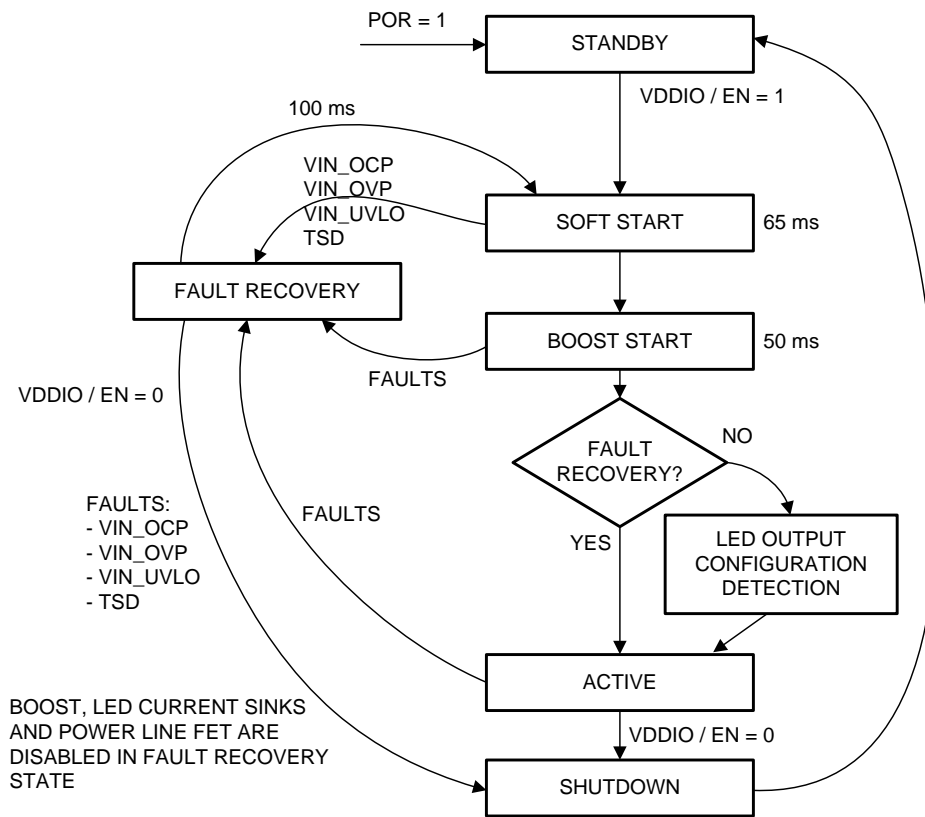

Figure 22. State Diagram

Device Functional Modes (continued)

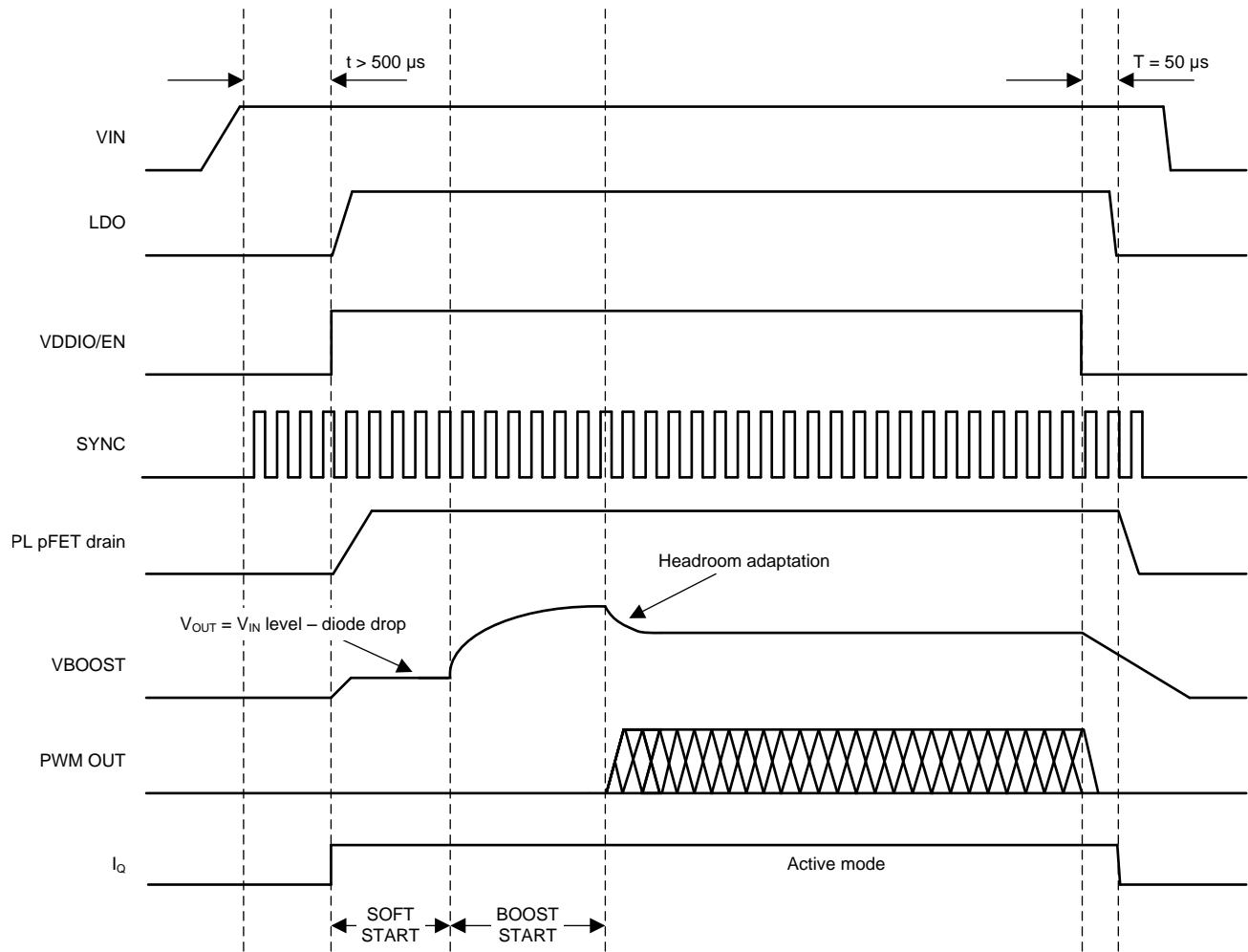

Figure 23. Timing Diagram for the Typical Start-Up and Shutdown

## 9 Application and Implementation

### NOTE

Information in the following applications sections is not part of the TI component specification, and TI does not warrant its accuracy or completeness. TI's customers are responsible for determining suitability of components for their purposes. Customers should validate and test their design implementation to confirm system functionality.

### 9.1 Application Information

The LP8861-Q1 is designed for automotive applications, and an input voltage  $V_{IN}$  is intended to be connected to the car battery. Device circuitry is powered from the internal LDO which, alternatively, can be used as external VDD voltage — in that case, external voltage must be in the 4.5-V to 5.5-V range.

The LP8861-Q1 uses a simple four-wire control:

- VDDIO/EN for enable
- PWM input for brightness control
- SYNC pin for boost synchronisation (optional)
- FAULT output to indicate fault condition (optional)

### 9.2 Typical Applications

#### 9.2.1 Typical Application for 4 LED Strings

Figure 24 shows the typical application for LP8861-Q1 which supports 4 LED strings with maximum current 100 mA and boost switching frequency of 300 kHz.

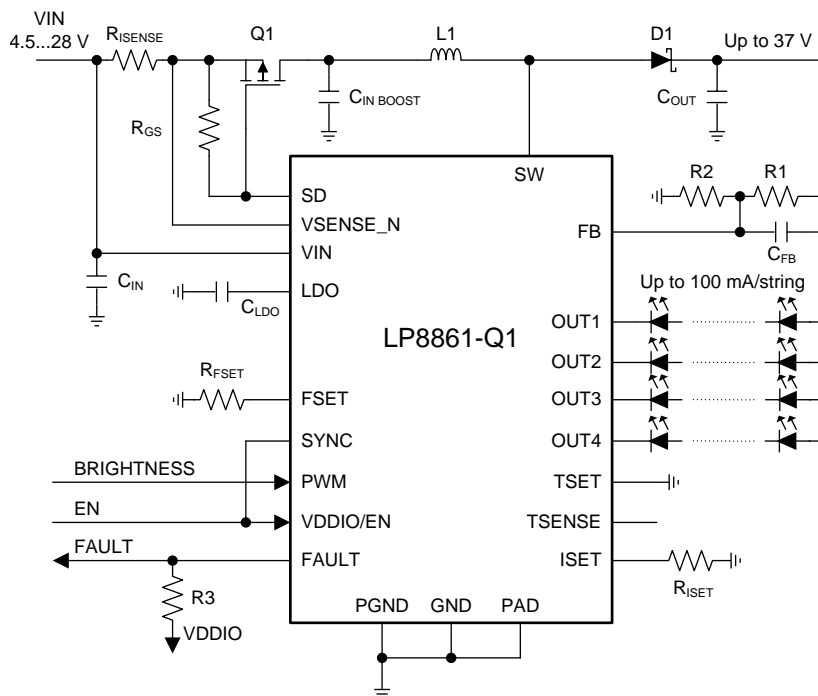

Figure 24. Typical Application for Four Strings 100 mA/String Configuration

## Typical Applications (continued)

### 9.2.1.1 Design Requirements

DESIGN PARAMETER	VALUE
VIN voltage range	4.5...28 V
LED string	4 x 8 LEDs (30 V)
LED string current	100 mA
Max boost voltage	37 V
Boost switching frequency	300 kHz
External boost sync	not used
Boost spread spectrum	enabled
L1	33 μH
CIN	10 μF 50 V
CIN BOOST	2 x 10-μF, 50-V ceramic + 33-μF, 50-V electrolytic
COUT	2 x 10-μF, 50-V ceramic + 33-μF, 50-V electrolytic
CLDO	1 μF 10 V
C <sub>FB</sub>	15 pF
R <sub>ISET</sub>	24 kΩ
R <sub>FSET</sub>	210 kΩ
R <sub>ISENSE</sub>	50 mΩ
R1	750 kΩ
R2	130 kΩ
R3	10 kΩ
R <sub>GS</sub>	20 kΩ

### 9.2.1.2 Detailed Design Procedure

#### 9.2.1.2.1 Inductor Selection

There are two main considerations when choosing an inductor; the inductor must not saturate, and the inductor current ripple must be small enough to achieve the desired output voltage ripple. Different saturation current rating specifications are followed by different manufacturers so attention must be given to details. Saturation current ratings are typically specified at 25°C. However, ratings at the maximum ambient temperature of application should be requested from the manufacturer. Shielded inductors radiate less noise and are preferred. The saturation current must be greater than the sum of the maximum load current and the worst-case average to peak inductor current. Equation 10 shows the worst-case conditions:

$$I_{SAT} > \frac{I_{OUTMAX}}{D'} + I_{RIPPLE} \quad \text{For Boost}$$

$$\text{Where } I_{RIPPLE} = \frac{(V_{OUT} - V_{IN})}{(2 \times L \times f)} \times \frac{V_{IN}}{V_{OUT}}$$

$$\text{Where } D = \frac{(V_{OUT} - V_{IN})}{(V_{OUT})} \text{ and } D' = (1 - D)$$

- I<sub>RIPPLE</sub> - peak inductor current
- I<sub>OUTMAX</sub> - maximum load current
- V<sub>IN</sub> - minimum input voltage in application
- L - min inductor value including worst case tolerances
- f - minimum switching frequency
- V<sub>OUT</sub> - output voltage
- D - Duty Cycle for CCM Operation
- V<sub>OUT</sub> - Output Voltage

(10)

As a result the inductor should be selected according to the  $I_{SAT}$ . A more conservative and recommended approach is to choose an inductor that has a saturation current rating greater than the maximum current limit. A saturation current rating at least 3 A is recommended for most applications. See [Table 2](#) for inductance recommendation for the different switch frequency ranges. The inductor's resistance should be less than 300 m $\Omega$  for good efficiency.

See detailed information in *Understanding Boost Power Stages in Switch Mode Power Supplies (SLVA061)*. Power Stage Designer™ Tools can be used for the boost calculation: <http://www.ti.com/tool/powerstage-designer>.

#### 9.2.1.2.2 Output Capacitor Selection

A ceramic and electrolytic capacitors should have sufficient voltage rating. The DC-bias effect in ceramic capacitors can reduce the effective capacitance by up to 80%, which needs to be considered in capacitance value selection. Capacitance recommendation for different switching frequency range is shown in [Table 2](#). To minimize audible of noise ceramic capacitors their geometric size is usually minimized.

#### 9.2.1.2.3 Input Capacitor Selection

A ceramic and electrolytic capacitors should have sufficient voltage rating. The DC-bias effect in ceramic capacitors can reduce the effective capacitance by up to 80%, which needs to be considered in capacitance value selection. Capacitance recommendation for different switching frequency range is shown in [Table 2](#). To minimize audible of noise ceramic capacitors their geometric size is usually minimized.

#### 9.2.1.2.4 LDO Output Capacitor

A ceramic capacitor with at least 10-V voltage rating is recommended for the output capacitor of the LDO. The DC-bias effect in ceramic capacitors can reduce the effective capacitance by up to 80%, which needs to be considered in capacitance value selection. Typically a 1- $\mu$ F capacitor is sufficient.

#### 9.2.1.2.5 Diode

A Schottky diode should be used for the boost output diode. Ordinary rectifier diodes should not be used, because slow switching speeds and long recovery times degrade the efficiency and the load regulation. Diode rating for peak repetitive current should be greater than inductor peak current (up to 3 A) to ensure reliable operation. Average current rating should be greater than the maximum output current. Schottky diodes with a low forward drop and fast switching speeds are ideal for increasing efficiency. Choose a reverse breakdown voltage of the Schottky diode significantly larger than the output voltage.

#### 9.2.1.2.6 Power Line Transistor

A pFET transistor with necessary voltage rating ( $V_{DS}$  at least 5 V higher than max input voltage) should be used. Current rating for the FET should be the same as input peak current or greater. Transfer characteristic is very important for pFET.  $V_{GS}$  for open transistor must be less than  $V_{IN}$ . A 20-k $\Omega$  resistor between pFET gate and source is sufficient.

#### 9.2.1.2.7 Input Current Sense Resistor

A high-power 50-m $\Omega$  resistor should be used for sensing the boost input current. Power rating can be calculated from the input current and sense resistor resistance value. Increasing  $R_{ISENSE}$  decreases  $V_{IN}$  OCP current proportionally.

### 9.2.1.3 Application Curves

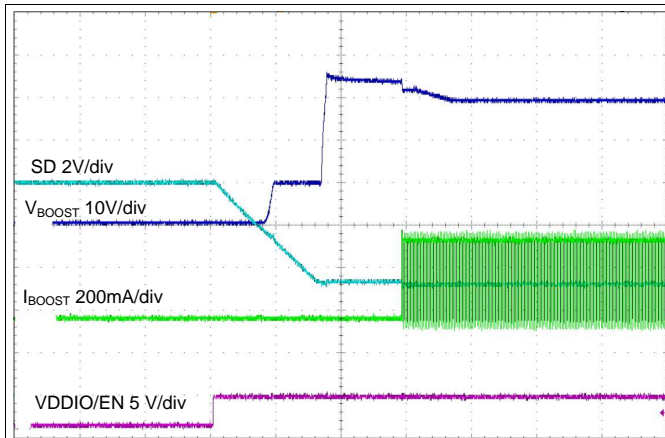

40ms/div  
 $f_{SW} = 300 \text{ kHz}$       $V_{IN} = 10 \text{ V}$   
 Brightness PWM 50% 100 Hz

Figure 25. Typical Start-up

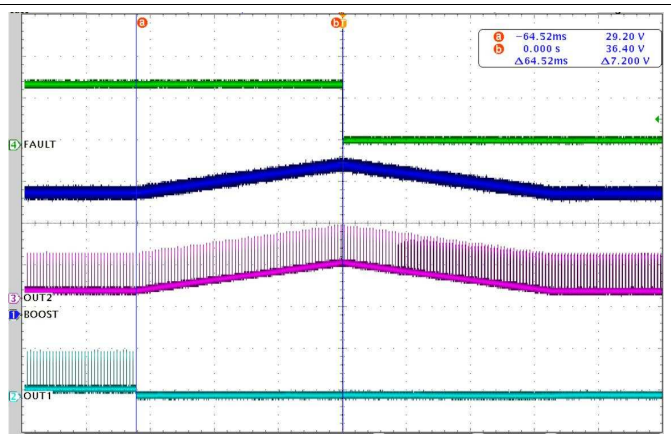

20ms/div     OUT1/OUT2/BOOST 10V/div     FAULT 2V/div

Figure 26. Open LED Fault

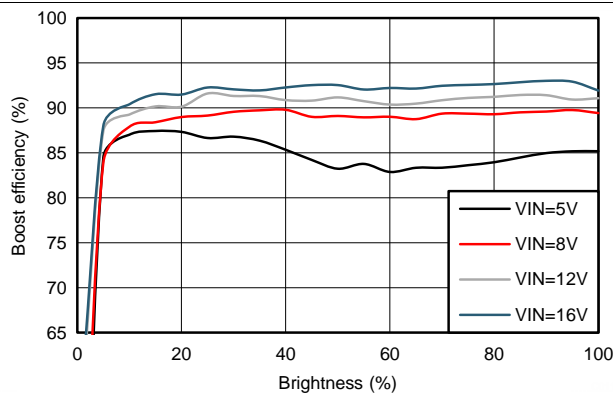

Load 4 strings, 8 LED per string      $f_{SW} = 300 \text{ kHz}$   
 $I = 100 \text{ mA/string}$  for  $V_{IN} = 12 \text{ V}$  and  $16 \text{ V}$   
 $I = 60 \text{ mA/string}$  for  $V_{IN} = 8 \text{ V}$   
 $I = 50 \text{ mA/string}$  for  $V_{IN} = 5 \text{ V}$

Figure 27. Boost Efficiency

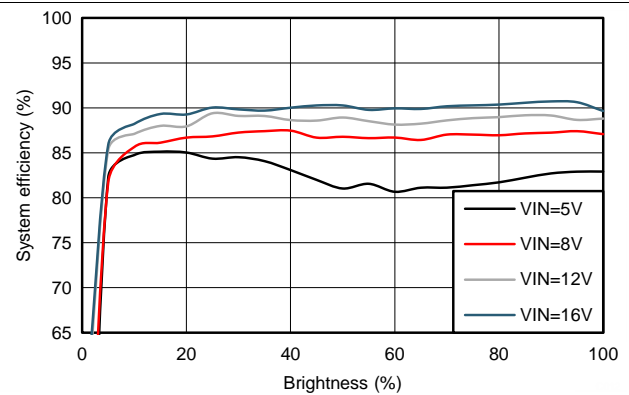

Load 4 strings, 8 LED per string      $f_{SW} = 300 \text{ kHz}$   
 $I = 100 \text{ mA/string}$  for  $V_{IN} = 12 \text{ V}$  and  $16 \text{ V}$   
 $I = 60 \text{ mA/string}$  for  $V_{IN} = 8 \text{ V}$   
 $I = 50 \text{ mA/string}$  for  $V_{IN} = 5 \text{ V}$

Figure 28. System Efficiency

### 9.2.2 High Output Current Application

The LP8861-Q1 current sinks can be tied together to drive LED with higher current. To drive 200 mA per string 2 outputs can be connected together. All 4 outputs connected together can drive an up to 400-mA LED string. Device circuitry is powered from external VDD voltage.

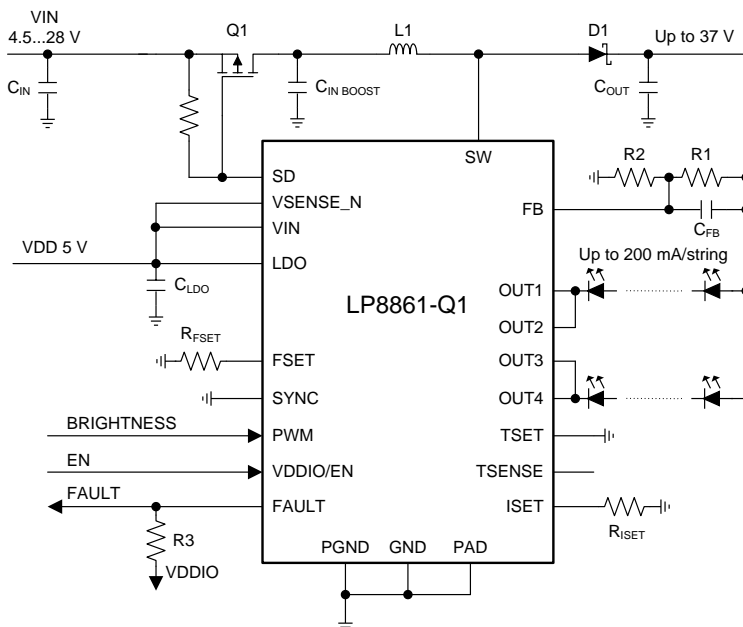

Figure 29. Two Strings 200 mA/String Configuration

### 9.2.2.1 Design Requirements

DESIGN PARAMETER	VALUE
$V_{IN}$ voltage range	4.5...28 V
LED string	2 × 8 LEDs (30 V)
LED string current	200 mA
Max boost voltage	37 V
Boost switching frequency	2.2 MHz
External boost sync	not used
Boost spread spectrum	disabled
L1	4.7 $\mu$ H
$C_{IN}$	10 $\mu$ F 50 V
$C_{IN\ BOOST}$	2 × 10- $\mu$ F, 50-V ceramic
$C_{OUT}$	3 × 10- $\mu$ F, 50-V ceramic
$C_{LDO}$	1 $\mu$ F 10 V
$C_{FB}$	4.7 pF
$R_{ISET}$	24 k $\Omega$
$R_{FSET}$	24 k $\Omega$
R1	750 k $\Omega$
R2	130 k $\Omega$
R3	10 k $\Omega$
$R_{GS}$	20 k $\Omega$

### 9.2.2.2 Detailed Design Procedure

See [Detailed Design Procedure](#).

### 9.2.2.3 Application Curves

See [Application Curves](#).

### 9.2.3 SEPIC Mode Application

When LED string voltage can be above or below  $V_{IN}$  voltage, SEPIC configuration can be used. The SW pin voltage is equal to the sum of the input voltage and output voltage in SEPIC mode — this fact limits the maximum input voltage in this mode. LED current sinks not used should be connected to ground. External frequency can be used to synchronize boost/SEPIC switching frequency, and external frequency can be modulated to spread switching frequency spectrum.

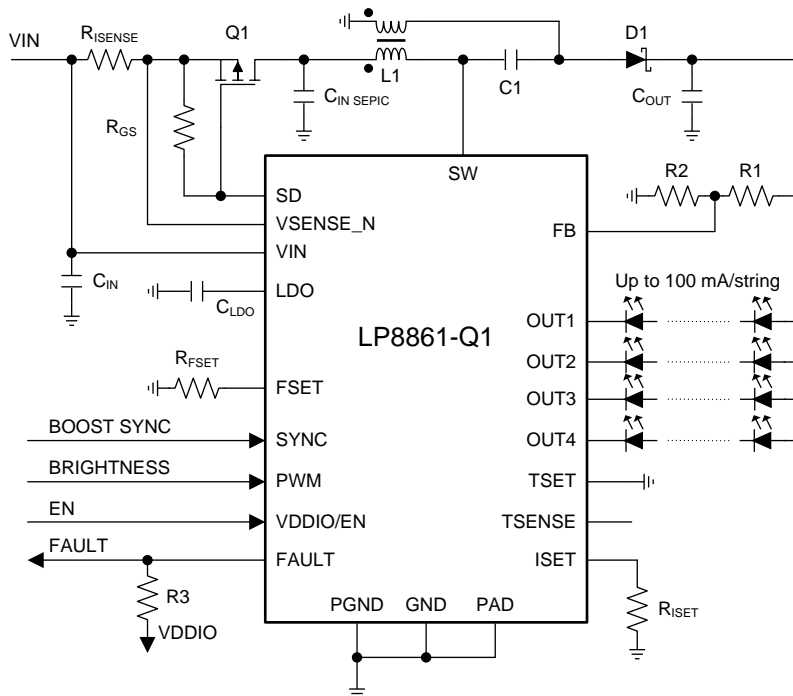

**Figure 30. SEPIC Mode, 4 Strings 100 mA/String Configuration**

### 9.2.3.1 Design Requirements

DESIGN PARAMETER	VALUE
V <sub>IN</sub> voltage range	4.5...30 V
LED string	4 × 4 LEDs (14.5 V)
LED string current	100 mA
Max boost voltage	17.5 V
Boost switching frequency	300 kHz
External boost sync	used
Boost spread spectrum	not available with external sync
L1	33 μH
C <sub>IN</sub>	10 μF 50 V
C <sub>IN SEPIC</sub>	2 × 10-μF, 50-V ceramic + 33-μF 50-V electrolytic
C1	10-μF 50-V ceramic
C <sub>OUT</sub>	2 × 10-μF, 50-V ceramic + 33-μF 50-V electrolytic
C <sub>LDO</sub>	1 μF 10 V
R <sub>ISET</sub>	24 kΩ
R <sub>FSET</sub>	210 kΩ
R <sub>ISENSE</sub>	50 mΩ
R1	390 kΩ
R2	130 kΩ
R3	10 kΩ
R <sub>GS</sub>	20 kΩ

### 9.2.3.2 Detailed Design Procedure

See [Detailed Design Procedure](#) for external component recommendations. The *Power Stage Designer™ Tools* can be use for defining SEPIC component current and voltage ratings according to application: <http://www.ti.com/tool/powerstage-designer>

#### 9.2.3.2.1 Diode

A Schottky diode with a low forward drop and fast switching speed should be used for the SEPIC output diode. Do not use ordinary rectifier diodes, because slow switching speeds and long recovery times degrade the efficiency and load regulation. The diode must be able to handle peak repetitive current greater than the integrated FET peak current (SW pin limit), thus 3 A or higher must be used to ensure reliable operation. Average current rating should be greater than the maximum output current. Choose a diode with reverse breakdown larger than the sum of input voltage and output voltage.

#### 9.2.3.2.2 Inductor

Coupled or uncoupled inductors can be used in SEPIC mode. Coupled inductor typically provides better efficiency. *Power Stage Designer™ Tools* can be used for the SEPIC inductance calculation: <http://www.ti.com/tool/powerstage-designer>.

### 9.2.3.3 Application Curves

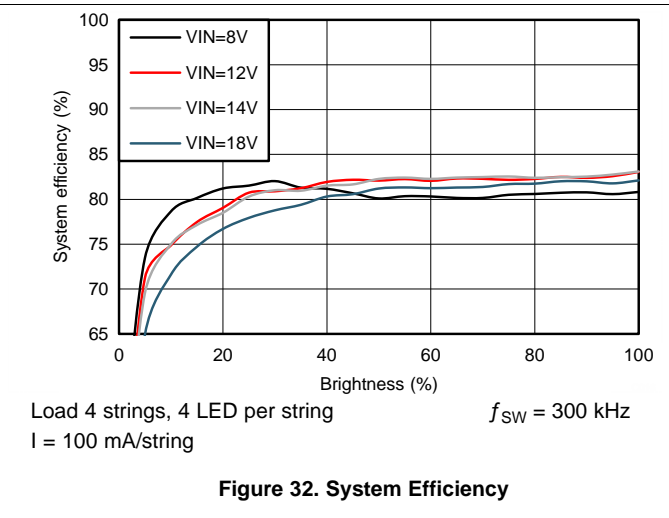
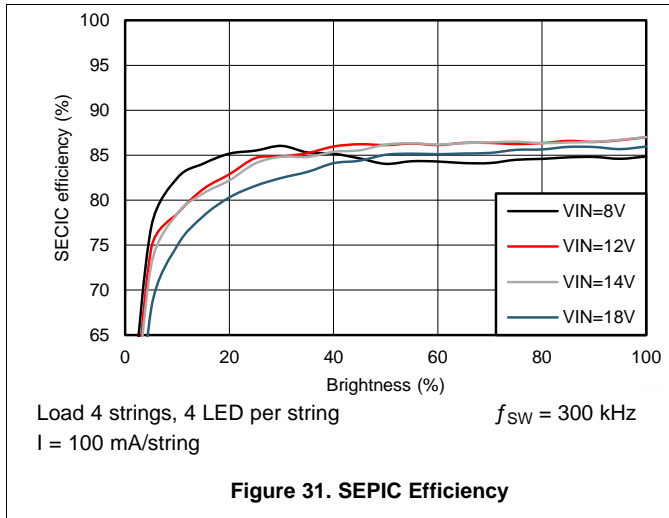

### 9.2.4 Application with Temperature Based LED Current De-rating

The LP8861-Q1 is able to protect connected LED strings from overheating. LED current versus temperature behavior can be adjusted with external resistor as described in [LED Current Dimming With External Temperature Sensor](#).

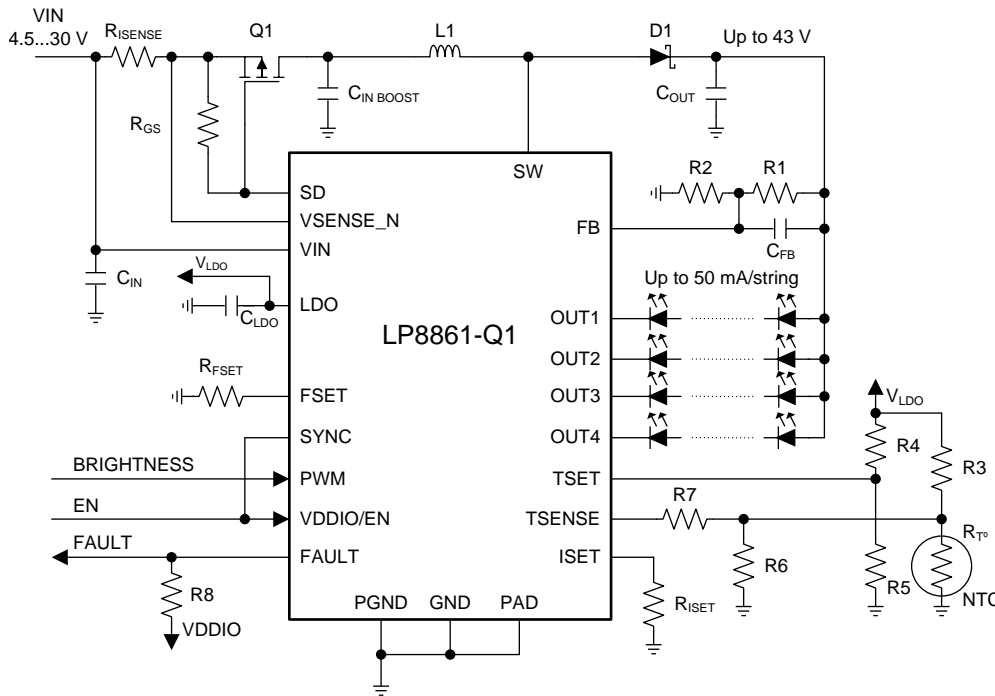

Figure 33. Temperature Based LED Current De-rating

### 9.2.4.1 Design Requirements

DESIGN PARAMETER	VALUE
V <sub>IN</sub> voltage range	4.5...30 V
LED string	4 × 9 LEDs (33 V)
LED string current	50 mA
Max boost voltage	43 V
Boost switching frequency	400 kHz
External boost sync	not used
Boost spread spectrum	enabled
L1	33 μH
C <sub>IN</sub>	10-μF 50-V ceramic
C <sub>IN BOOST</sub>	2 × 10-μF, 50-V ceramic + 33-μF, 50-V electrolytic
C <sub>OUT</sub>	2 × 10-μF, 50-V ceramic + 33-μF, 50-V electrolytic
C <sub>LDO</sub>	1 μF 10 V
C <sub>FB</sub>	15 pF
R <sub>ISET</sub>	48 kΩ
R <sub>FSET</sub>	160 kΩ
R <sub>ISENSE</sub>	50 mΩ
R1	866 kΩ
R2	130 kΩ
R3	12 kΩ
R4	10 kΩ
R5	1.8 kΩ
R6	82 kΩ
R7	16 kΩ
R8	10 kΩ
RT	10 kΩ @ 25°C
R <sub>CS</sub>	20 kΩ

### 9.2.4.2 Detailed Design Procedure

See [Detailed Design Procedure](#).

### 9.2.4.3 Application Curve

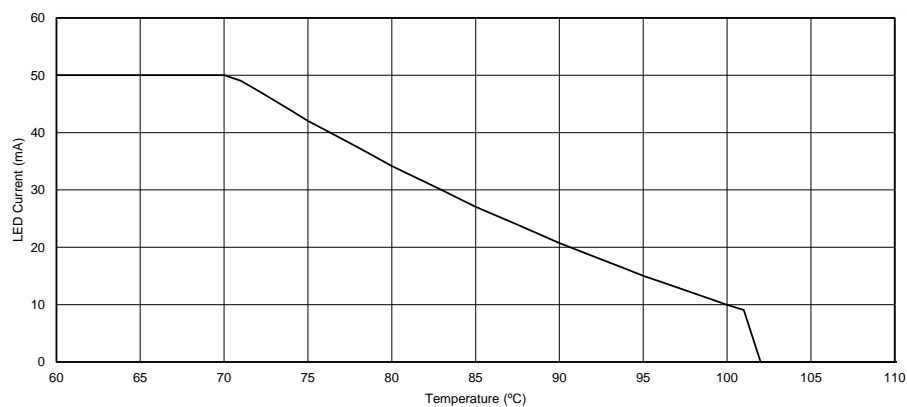

**Figure 34. LED Current vs Temperature**

## 10 Power Supply Recommendations

The LP8861-Q1 device is designed to operate from a car battery. The device should be protected from reverse voltage polarity and voltage dump over 50 V. The resistance of the input supply rail must be low enough so that the input current transient does not cause too high drop at the LP8861-Q1 VIN pin. If the input supply is connected by using long wires additional bulk capacitance may be required in addition to the ceramic bypass capacitors in the V<sub>IN</sub> line.

## 11 Layout

### 11.1 Layout Guidelines

[Figure 35](#) is a layout recommendation for the LP8861-Q1 used to demonstrate the principles of good layout. This layout can be adapted to the actual application layout if or where possible. It is important that all boost components are close to the chip, and the high current traces must be wide enough. By placing boost components on one side of the chip it is easy to keep the ground plane intact below the high current paths. This way other chip pins can be routed more easily without splitting the ground plane. Bypass LDO capacitor must as close as possible to the device.

Here are some main points to help the PCB layout work:

- Current loops need to be minimized:
  - For low frequency the minimal current loop can be achieved by placing the boost components as close as possible to the SW and PGND pins. Input and output capacitor grounds need to be close to each other to minimize current loop size
  - Minimal current loops for high frequencies can be achieved by making sure that the ground plane is intact under the current traces. High-frequency return currents try to find route with minimum impedance, which is the route with minimum loop area, not necessarily the shortest path. Minimum loop area is formed when return current flows just under the positive current route in the ground plane, if the ground plane is intact under the route
- GND plane needs to be intact under the high current boost traces to provide shortest possible return path and smallest possible current loops for high frequencies.
- Current loops when the boost switch is conducting and not conducting need to be on the same direction in optimal case.
- Inductors must be placed so that the current flows in the same direction as in the current loops. Rotating inductor 180° changes current direction.
- Use separate power and noise-free grounds. Power ground is used for boost converter return current and noise-free ground for more sensitive signals, like LDO bypass capacitor grounding as well as grounding the GND pin of the device itself.
- Boost output feedback voltage to LEDs need to be taken out *after* the output capacitors, not straight from the diode cathode.
- Place LDO 1-μF bypass capacitor as close as possible to the LDO pin.
- Input and output capacitors need strong grounding (wide traces, many vias to GND plane).
- If two output capacitors are used they need symmetrical layout to get both capacitors working ideally.
- Output ceramic capacitors have DC-bias effect. If the output capacitance is too low, it can cause boost to become unstable on some loads; this increases EMI. DC bias characteristics need to be obtained from the component manufacturer; DC bias is not taken into account on component tolerance. X5R/X7R capacitors are recommended.

## 11.2 Layout Example

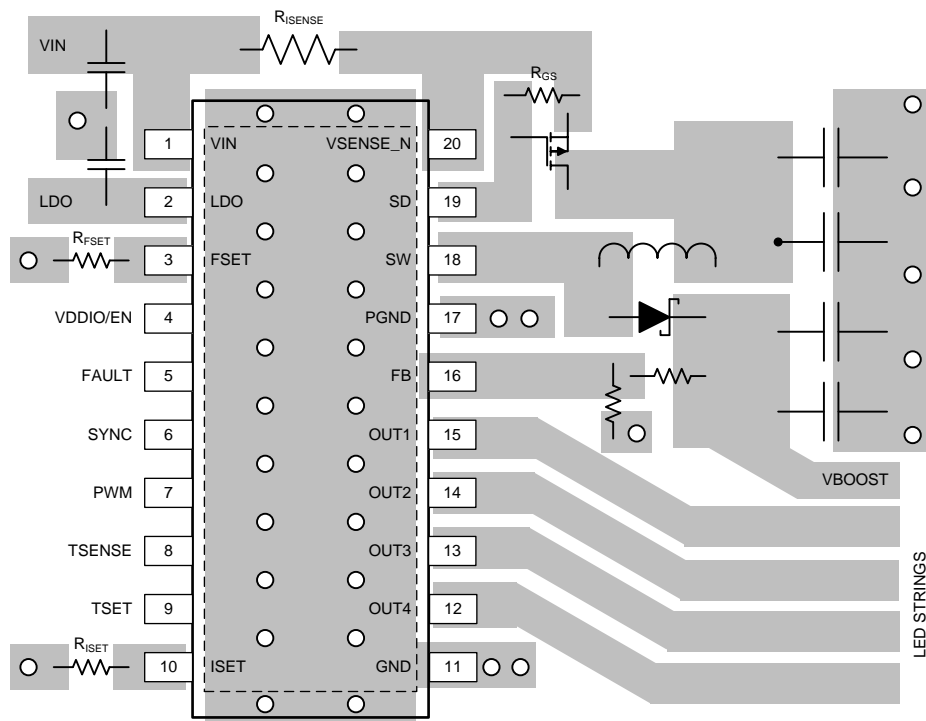

Figure 35. LP8861-Q1 Layout

## 12 Device and Documentation Support

### 12.1 Device Support

#### 12.1.1 Third-Party Products Disclaimer

TI'S PUBLICATION OF INFORMATION REGARDING THIRD-PARTY PRODUCTS OR SERVICES DOES NOT CONSTITUTE AN ENDORSEMENT REGARDING THE SUITABILITY OF SUCH PRODUCTS OR SERVICES OR A WARRANTY, REPRESENTATION OR ENDORSEMENT OF SUCH PRODUCTS OR SERVICES, EITHER ALONE OR IN COMBINATION WITH ANY TI PRODUCT OR SERVICE.

### 12.2 Documentation Support

#### 12.2.1 Related Documentation

For additional information, see the following:

- [Using the LP8861-Q1EVM Evaluation Module](#)
- [PowerPAD™ Thermally Enhanced Package Application Note](#)
- TI Application Note [Understanding Boost Power Stages in Switch Mode Power Supplies](#)
- [Power Stage Designer™ Tools](#), <http://www.ti.com/tool/powerstage-designer>

#### 12.3 Receiving Notification of Documentation Updates

To receive notification of documentation updates, navigate to the device product folder on ti.com. In the upper right corner, click on *Alert me* to register and receive a weekly digest of any product information that has changed. For change details, review the revision history included in any revised document.

#### 12.4 Community Resources

The following links connect to TI community resources. Linked contents are provided "AS IS" by the respective contributors. They do not constitute TI specifications and do not necessarily reflect TI's views; see TI's [Terms of Use](#).

**TI E2E™ Online Community** *TI's Engineer-to-Engineer (E2E) Community*. Created to foster collaboration among engineers. At e2e.ti.com, you can ask questions, share knowledge, explore ideas and help solve problems with fellow engineers.

**Design Support** *TI's Design Support* Quickly find helpful E2E forums along with design support tools and contact information for technical support.

#### 12.5 Trademarks

E2E is a trademark of Texas Instruments.  
Excel is a registered trademark of Microsoft Corporation.  
All other trademarks are the property of their respective owners.

#### 12.6 Electrostatic Discharge Caution



These devices have limited built-in ESD protection. The leads should be shorted together or the device placed in conductive foam during storage or handling to prevent electrostatic damage to the MOS gates.

#### 12.7 Glossary

**SLYZ022** — *TI Glossary*.

This glossary lists and explains terms, acronyms, and definitions.

## 13 Mechanical, Packaging, and Orderable Information

The following pages include mechanical, packaging, and orderable information. This information is the most current data available for the designated devices. This data is subject to change without notice and revision of this document. For browser-based versions of this data sheet, refer to the left-hand navigation.

**PACKAGING INFORMATION**

Orderable Device	Status (1)	Package Type	Package Drawing	Pins	Package Qty	Eco Plan (2)	Lead finish/ Ball material (6)	MSL Peak Temp (3)	Op Temp (°C)	Device Marking (4/5)	Samples
LP8861QPWPRQ1	ACTIVE	HTSSOP	PWP	20	2000	RoHS & Green	NIPDAU	Level-2-260C-1 YEAR	-40 to 125	LP8861Q	Samples

(1) The marketing status values are defined as follows:

**ACTIVE:** Product device recommended for new designs.

**LIFEBUY:** TI has announced that the device will be discontinued, and a lifetime-buy period is in effect.

**NRND:** Not recommended for new designs. Device is in production to support existing customers, but TI does not recommend using this part in a new design.

**PREVIEW:** Device has been announced but is not in production. Samples may or may not be available.

**OBSOLETE:** TI has discontinued the production of the device.

(2) **RoHS:** TI defines "RoHS" to mean semiconductor products that are compliant with the current EU RoHS requirements for all 10 RoHS substances, including the requirement that RoHS substance do not exceed 0.1% by weight in homogeneous materials. Where designed to be soldered at high temperatures, "RoHS" products are suitable for use in specified lead-free processes. TI may reference these types of products as "Pb-Free".

**RoHS Exempt:** TI defines "RoHS Exempt" to mean products that contain lead but are compliant with EU RoHS pursuant to a specific EU RoHS exemption.

**Green:** TI defines "Green" to mean the content of Chlorine (Cl) and Bromine (Br) based flame retardants meet JS709B low halogen requirements of <=1000ppm threshold. Antimony trioxide based flame retardants must also meet the <=1000ppm threshold requirement.

(3) MSL, Peak Temp. - The Moisture Sensitivity Level rating according to the JEDEC industry standard classifications, and peak solder temperature.

(4) There may be additional marking, which relates to the logo, the lot trace code information, or the environmental category on the device.

(5) Multiple Device Markings will be inside parentheses. Only one Device Marking contained in parentheses and separated by a "~" will appear on a device. If a line is indented then it is a continuation of the previous line and the two combined represent the entire Device Marking for that device.

(6) Lead finish/Ball material - Orderable Devices may have multiple material finish options. Finish options are separated by a vertical ruled line. Lead finish/Ball material values may wrap to two lines if the finish value exceeds the maximum column width.

**Important Information and Disclaimer:** The information provided on this page represents TI's knowledge and belief as of the date that it is provided. TI bases its knowledge and belief on information provided by third parties, and makes no representation or warranty as to the accuracy of such information. Efforts are underway to better integrate information from third parties. TI has taken and continues to take reasonable steps to provide representative and accurate information but may not have conducted destructive testing or chemical analysis on incoming materials and chemicals. TI and TI suppliers consider certain information to be proprietary, and thus CAS numbers and other limited information may not be available for release.

In no event shall TI's liability arising out of such information exceed the total purchase price of the TI part(s) at issue in this document sold by TI to Customer on an annual basis.

**TAPE AND REEL INFORMATION**

**QUADRANT ASSIGNMENTS FOR PIN 1 ORIENTATION IN TAPE**

\*All dimensions are nominal

Device	Package Type	Package Drawing	Pins	SPQ	Reel Diameter (mm)	Reel Width W1 (mm)	A0 (mm)	B0 (mm)	K0 (mm)	P1 (mm)	W (mm)	Pin1 Quadrant
LP8861QPWPRQ1	HTSSOP	PWP	20	2000	330.0	16.4	6.95	7.0	1.4	8.0	16.0	Q1
LP8861QPWPRQ1	HTSSOP	PWP	20	2000	330.0	16.4	6.95	7.1	1.6	8.0	16.0	Q1

**TAPE AND REEL BOX DIMENSIONS**

\*All dimensions are nominal

Device	Package Type	Package Drawing	Pins	SPQ	Length (mm)	Width (mm)	Height (mm)
LP8861QPWPRQ1	HTSSOP	PWP	20	2000	356.0	356.0	35.0
LP8861QPWPRQ1	HTSSOP	PWP	20	2000	350.0	350.0	43.0

## THERMAL PAD MECHANICAL DATA

### PWP (R-PDSO-G20) PowerPAD™ SMALL PLASTIC OUTLINE

#### THERMAL INFORMATION

This PowerPAD™ package incorporates an exposed thermal pad that is designed to be attached to a printed circuit board (PCB). The thermal pad must be soldered directly to the PCB. After soldering, the PCB can be used as a heatsink. In addition, through the use of thermal vias, the thermal pad can be attached directly to the appropriate copper plane shown in the electrical schematic for the device, or alternatively, can be attached to a special heatsink structure designed into the PCB. This design optimizes the heat transfer from the integrated circuit (IC).

For additional information on the PowerPAD package and how to take advantage of its heat dissipating abilities, refer to Technical Brief, PowerPAD Thermally Enhanced Package, Texas Instruments Literature No. SLMA002 and Application Brief, PowerPAD Made Easy, Texas Instruments Literature No. SLMA004. Both documents are available at [www.ti.com](http://www.ti.com).

The exposed thermal pad dimensions for this package are shown in the following illustration.

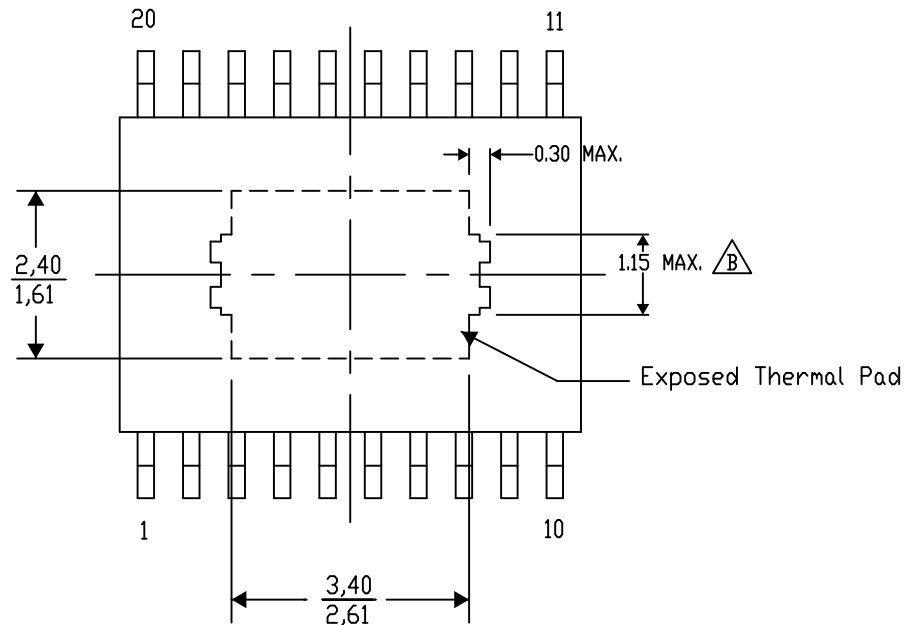

Top View

Exposed Thermal Pad Dimensions

4206332-15/AO 01/16

NOTE: A. All linear dimensions are in millimeters

 Exposed tie strap features may not be present.

PowerPAD is a trademark of Texas Instruments

PWP (R-PDSO-G20)

PowerPAD™ PLASTIC SMALL OUTLINE

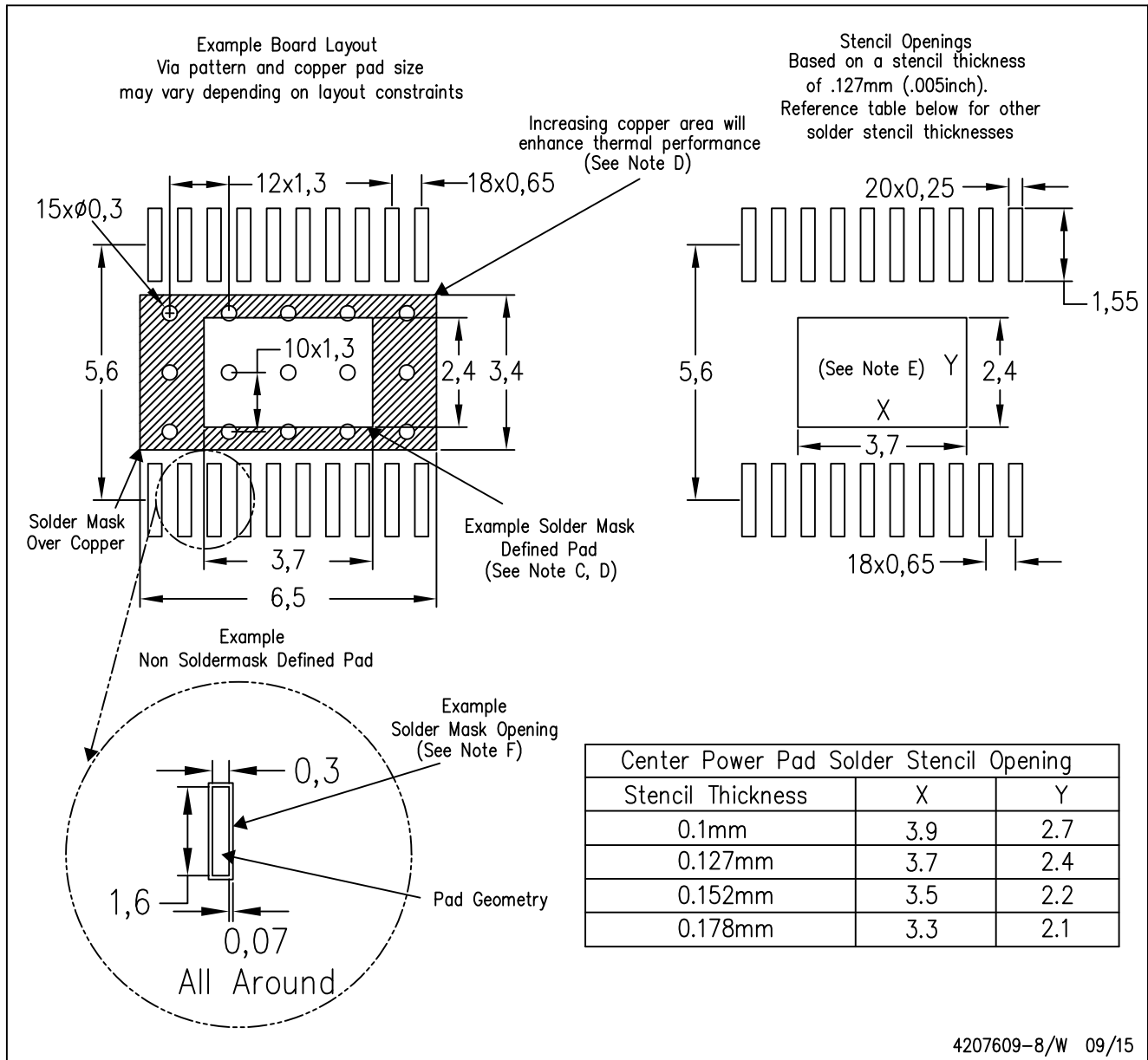

- NOTES:
- A. All linear dimensions are in millimeters.
  - B. This drawing is subject to change without notice.
  - C. Customers should place a note on the circuit board fabrication drawing not to alter the center solder mask defined pad.
  - D. This package is designed to be soldered to a thermal pad on the board. Refer to Technical Brief, PowerPad Thermally Enhanced Package, Texas Instruments Literature No. SLMA002, SLMA004, and also the Product Data Sheets for specific thermal information, via requirements, and recommended board layout. These documents are available at [www.ti.com](http://www.ti.com) <<http://www.ti.com>>. Publication IPC-7351 is recommended for alternate designs.
  - E. Laser cutting apertures with trapezoidal walls and also rounding corners will offer better paste release. Customers should contact their board assembly site for stencil design recommendations. Example stencil design based on a 50% volumetric metal load solder paste. Refer to IPC-7525 for other stencil recommendations.
  - F. Customers should contact their board fabrication site for solder mask tolerances between and around signal pads.



PWP (R-PDSO-G20)

PowerPAD™ PLASTIC SMALL OUTLINE

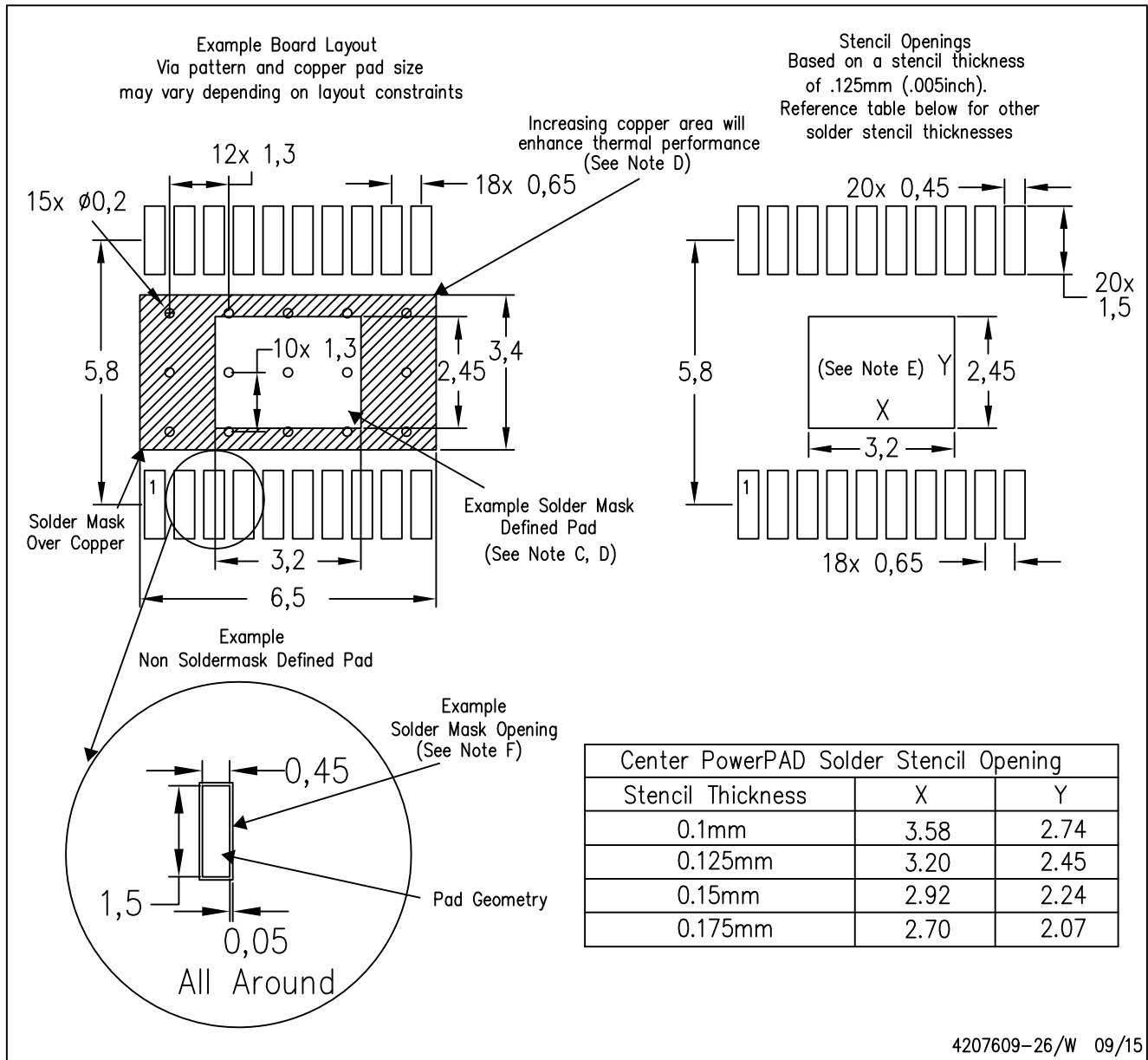

- NOTES:
- All linear dimensions are in millimeters.
  - This drawing is subject to change without notice.
  - Customers should place a note on the circuit board fabrication drawing not to alter the center solder mask defined pad.
  - This package is designed to be soldered to a thermal pad on the board. Refer to Technical Brief, PowerPad Thermally Enhanced Package, Texas Instruments Literature No. SLMA002, SLMA004, and also the Product Data Sheets for specific thermal information, via requirements, and recommended board layout. These documents are available at [www.ti.com](http://www.ti.com) <<http://www.ti.com>>. Publication IPC-7351 is recommended for alternate designs.
  - Laser cutting apertures with trapezoidal walls and also rounding corners will offer better paste release. Customers should contact their board assembly site for stencil design recommendations. Example stencil design based on a 50% volumetric metal load solder paste. Refer to IPC-7525 for other stencil recommendations.
  - Customers should contact their board fabrication site for solder mask tolerances between and around signal pads.

## IMPORTANT NOTICE AND DISCLAIMER

TI PROVIDES TECHNICAL AND RELIABILITY DATA (INCLUDING DATA SHEETS), DESIGN RESOURCES (INCLUDING REFERENCE DESIGNS), APPLICATION OR OTHER DESIGN ADVICE, WEB TOOLS, SAFETY INFORMATION, AND OTHER RESOURCES "AS IS" AND WITH ALL FAULTS, AND DISCLAIMS ALL WARRANTIES, EXPRESS AND IMPLIED, INCLUDING WITHOUT LIMITATION ANY IMPLIED WARRANTIES OF MERCHANTABILITY, FITNESS FOR A PARTICULAR PURPOSE OR NON-INFRINGEMENT OF THIRD PARTY INTELLECTUAL PROPERTY RIGHTS.

These resources are intended for skilled developers designing with TI products. You are solely responsible for (1) selecting the appropriate TI products for your application, (2) designing, validating and testing your application, and (3) ensuring your application meets applicable standards, and any other safety, security, regulatory or other requirements.

These resources are subject to change without notice. TI grants you permission to use these resources only for development of an application that uses the TI products described in the resource. Other reproduction and display of these resources is prohibited. No license is granted to any other TI intellectual property right or to any third party intellectual property right. TI disclaims responsibility for, and you will fully indemnify TI and its representatives against, any claims, damages, costs, losses, and liabilities arising out of your use of these resources.

TI's products are provided subject to [TI's Terms of Sale](#) or other applicable terms available either on [ti.com](https://www.ti.com) or provided in conjunction with such TI products. TI's provision of these resources does not expand or otherwise alter TI's applicable warranties or warranty disclaimers for TI products.

TI objects to and rejects any additional or different terms you may have proposed.

Mailing Address: Texas Instruments, Post Office Box 655303, Dallas, Texas 75265  
Copyright © 2023, Texas Instruments Incorporated